

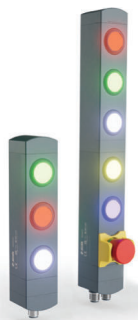

**BN series**  
**IO-Link control device units**



## General data



The modular control device units of Pizzato Elettrica's BN IO-Link series introduce IO-Link technology to the control device units of the BN series.

BN control device units with IO-Link technology enable accurate monitoring of all operating phases, immediate detection of any anomalies and quick and easy wiring thanks to plug & play technology.

The illuminated control device units of the BN series device with IO-Link, equipped with RGB LEDs, can be configured to emit the preferred colours with varying levels of light intensity, to blink at various frequencies or to fade out. The buttons are equipped with removable lenses that can be laser-marked for a resistant, indelible engraving. This allows customization of the lenses with a wide range of text and symbols, and replacement with lenses of a different colour or with different markings.

## IO-Link



**IO-Link** IO-Link is an open communication standard for sensors and actuators, defined by the PROFIBUS User Organization (PNO). IO-Link technology is a point-to-point communication standard that connects sensors and actuators to the control system. As well as the cyclic operating data of the connected sensors and actuators, parameter and diagnostic data is also sent.

## Custom colour and RGB LEDs



The control devices of the BN series IO-Link control device unit can be illuminated, a solution to meet any requirements. As they have RGB LEDs, the buttons can be configured in a vast range of colours: red, green, blue, yellow, cyan, magenta and white. There are also 4 colours that can be configured by the user to customise the appearance of the control device unit to suit your own aesthetic and functional preferences. The brightness of the RGB LEDs can be adjusted via IO-Link to adapt to various environmental conditions, and the LEDs can also be set to blink at various frequencies and fade out.

## Removable and laser-markable lenses



With all product configurations, a number of devices can be installed that can also be illuminated via LEDs integrated in the device.

The buttons are equipped with removable lenses that can be laser-marked for a resistant, indelible engraving. This allows customization of the lenses with a wide range of text and symbols, and replacement with lenses of a different colour or with different markings. For a full list of available markings, see the Accessories chapter on page 375 General Catalogue Safety Devices.

## Protection guard for emergency stop button



The mushroom-shaped emergency stop button is provided with a yellow protection guard that serves to protect the device from shocks. The protection guard can also be provided with laser engraving in accordance with EN ISO 13850.

## Data and configuration



The BN Series control device unit exchanges with the IO-Link master data on the surrounding environment, such as:

- State of the buttons (or the different types of devices);
- State of the LEDs;
- Supply voltage;
- Temperature;
- Device usage time.

The system detects any out-of-range values in the monitored data. Device data can be displayed in real time.

## Plug & Play



The BN series IO-Link control device unit offers numerous advantages compared to traditional wired solutions. The Plug & Play technology makes the device easy to install without complex, time-consuming and costly wiring. This also means the device can be quickly replaced if it gets damaged or malfunctions, without having to dismantle whole parts of the plant.

## Protection against tampering

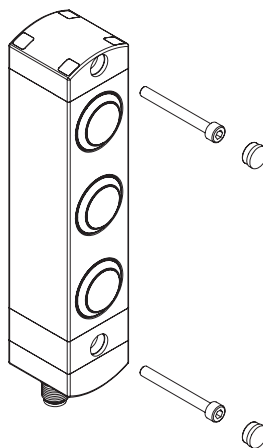

Each control device unit of the BN series is supplied complete with snap-on protection caps to be applied on the holes of the fixing screws. Not only do the caps prevent deposits of dirt from accumulating and simplify cleaning, they also prevent access to the fixing screws of the device, thereby offering increased protection against tampering.



## Selection diagram

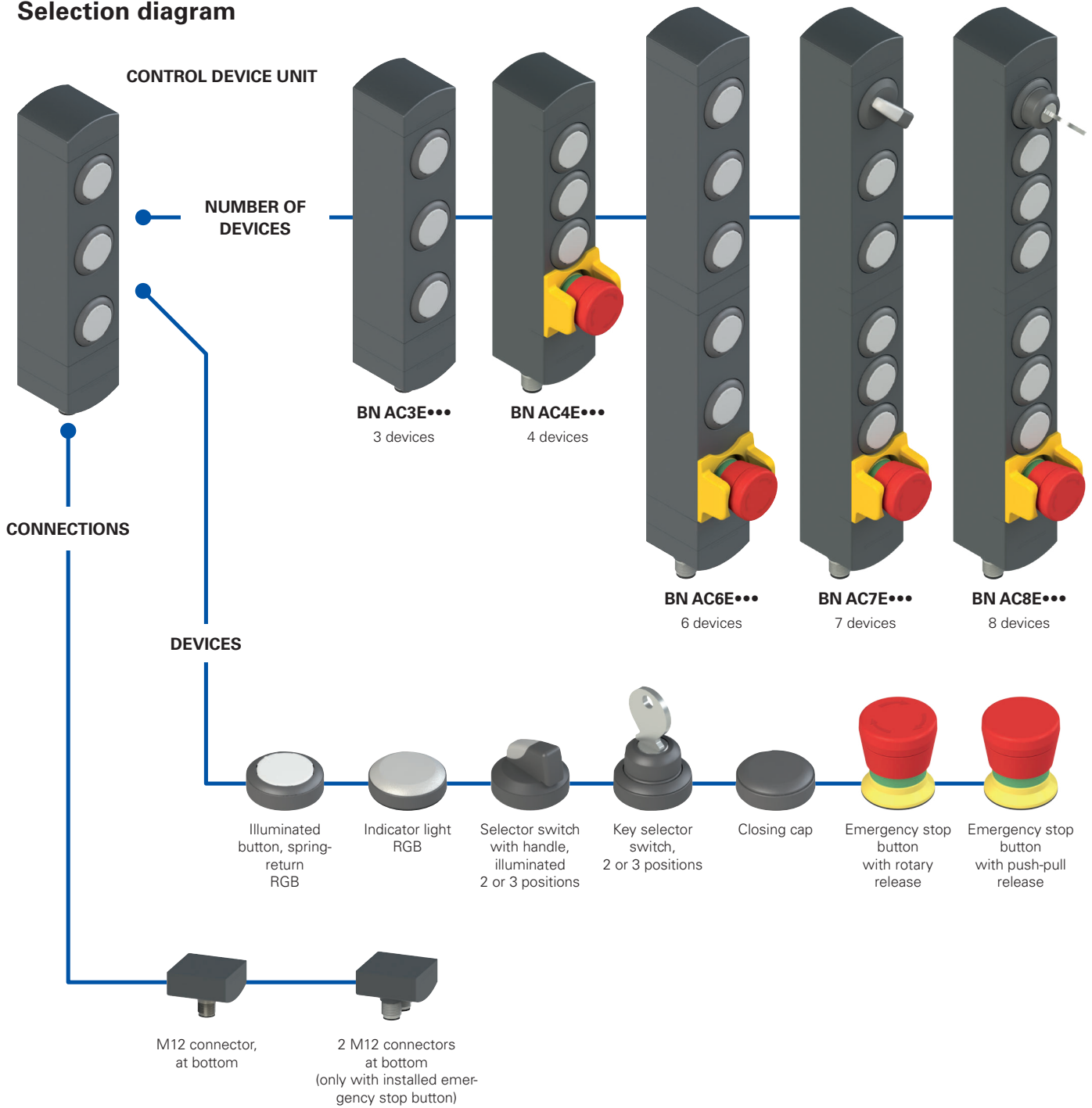

### Code structure

**Attention!** The feasibility of a code number does not mean the effective availability of a product. Please contact our sales office.

## BN AC3EA01

Number of devices	
<b>3</b>	3 devices
<b>4</b>	4 devices
<b>6</b>	6 devices
<b>7</b>	7 devices
<b>8</b>	8 devices

Button configuration	
<b>A01</b>	A01 configuration
<b>A02</b>	A02 configuration
...	other configurations on request

Operation	
<b>E</b>	IO-Link

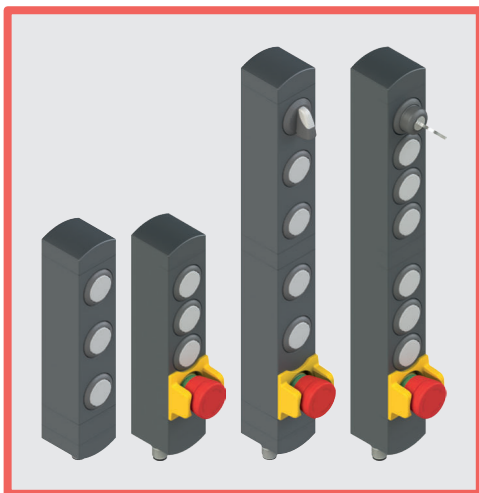

### Main features

- Modular control device unit with 3, 4, 6, 7 or 8 devices
- Rotatable fixing position
- Flush-mounted control devices
- Compact dimensions, minimal housing width
- Numerous control devices available

### Quality marks:



UL approval: E131787

### Features approved by UL

Electrical ratings: 24 Vdc Class 2, 0.2 A

Model BN with base module dimensions 40 mm by 38.5 mm by 145.5 mm:

Input Supplied by 24 Vdc, "Class 2" Source or limited voltage limited energy, 0.2 A max. (Maximum eight leds).

Output IO-Link (Serial data) 24 V dc, "Class 2"

Emergency Stop Button 24 Vac/dc "Class 2" 0.25 A Pilot Duty (Maximum one provided, silver contacts).

Emergency Stop Button 24 Vac/dc "Class 2" 0.1 A (Maximum one provided, golden contacts).

Model BN with base module dimensions 40 mm by 38.5 mm by 82.1 mm:

Input Supplied by 24 Vdc, "Class 2" Source or limited voltage limited energy, 0.2 A max. (Maximum four leds).

Output IO-Link (Serial data) 24 V dc, "Class 2"

Emergency Stop Button 24 Vac/dc "Class 2" 0.25 A Pilot Duty (Maximum one provided, silver contacts).

Emergency Stop Button 24 Vac/dc "Class 2" 0.1 A (Maximum one provided, golden contacts).

Environmental ratings: Type 1

### Technical data

Housing made of glass fibre reinforced technopolymer, self-extinguishing and shock-proof. Versions with integrated single or double M12 stainless steel connector.

Protection degree: IP65 acc. to EN 60529

### General data

Ambient temperature: -20°C ... +50°C  
 Storage temperature: -40°C ... +80°C  
 Fixing screws for the housing: 2 x M5, tightening torque 3 Nm  
 Fixing screws for turnable modules: Tightening torque of 0.8 ... 1.2 Nm  
 External protection fuse: 1 A type Gg or equivalent device

### Electrical data

Rated operating voltage  $U_e$ : 24 Vdc  $\pm$ 25% SELV/PELV  
 Max. operating current: 200 mA

### IO-Link specifications

Interface version and system specifications: see "Manufacturer declaration" available for download at <https://ioddfinder.io-link.com/>

The IODD and the IO-Link interface description are available for download at [www.pizzato.com](http://www.pizzato.com)

### Technical data of control devices

Mechanical endurance:  
 Spring-return button (RGB): 1 million operating cycles  
 Emergency stop button: 50,000 operating cycles  
 Selector switch: 300,000 operating cycles  
 Key selector switch: 50,000 operating cycles  
 30,000 operating cycles including removal of the key  
 130,000 (emergency stop button)

Safety parameter  $B_{10D}$ :

Actuating force:

Spring-return button (RGB):	min. 2.9 N	max. 4 N
Emergency stop button:	min. 20 N	max. 100 N
Selector switch:	min. 0.1 Nm	max. 1.5 Nm
Key selector switch:	min. 0.1 Nm	max. 1.3 Nm

### Technical data of contact blocks for emergency stop buttons (2NC)

Material of the contacts: gold-plated contacts  
 Contact type: Self-cleaning contacts with double interruption

Thermal current  $I_{th}$ : 0.1 A  
 Rated insulation voltage  $U_i$ : 32 Vac/dc  
 Rated impulse withstand voltage  $U_{imp}$ : 0.5 kV  
 Utilization category of the contact block: DC13;  $U_e = 24$  Vdc;  $I_e = 0.1$  A

### In compliance with standards:

IEC 60947-5-1, IEC 60947-5-5, EN ISO 13850, EN IEC 61131-9, UL 508, CSA C22.2 No.14

### Compliance with the requirements of:

Machinery Directive 2006/42/EC, Low Voltage Directive 2014/35/EU, EMC Directive 2014/30/EU, RoHS Directive 2011/65/EU.



## Description

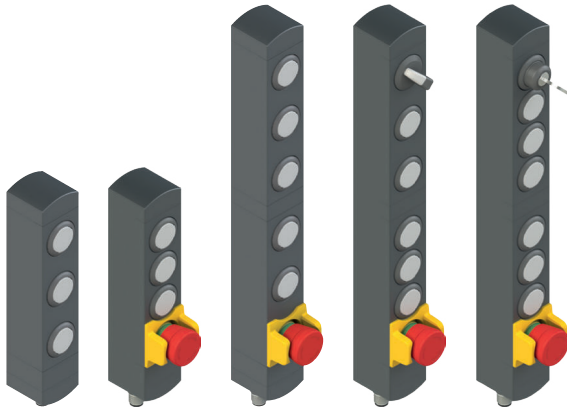

There's a new version of the Pizzato BN series control device unit that supports the modern IO-Link communication standard, opening the doors to new configuration, customisation and control options. The unit is quick and easy to update.

BN series IO-Link control device units can consist of one or two interconnected and rotatable modules: a distinctive feature of BN series control device units. Each module can take 3 or 4 control devices (e.g. buttons, emergency stop buttons, selectors) so up to 8 devices can be installed in a single control device unit. The buttons have RGB LEDs, while the selector has a white LED.

## Connection and power supply

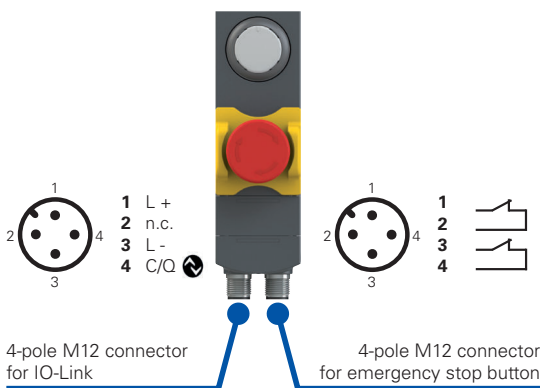

The standard version of the BN series IO-Link control device unit comes with a 4-pole M12 connector for communicating with the IO-Link master. If an emergency stop button is installed, a second 4-pole M12 connector must be used for the relevant voltage-free contacts. The 4-pole M12 connector used to communicate with the IO-Link master has just 3 wires (positive and negative for the power supply, and the data connection). The supply voltage of the IO-Link master (24 VDC) also supplies power to the BN series control device unit. The cable can also be unshielded. It must have a max. length of 20 m.

## Customisable LED mode

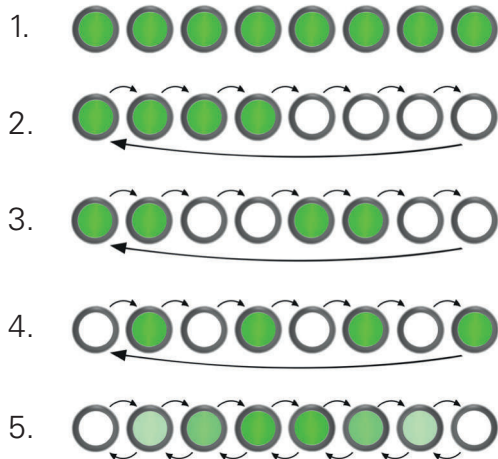

The state and colour of the RGB LEDs on the butt of the BN series IO-Link control device unit can be set to different modes, including:

1. Fixed light on;
2. Light blinking at 0.5 Hz;
3. Light blinking at 1 Hz;
4. Light blinking at 2 Hz;
5. Light fading out.

Night mode can also be set on the above types, dimming the brightness from "HIGH" to "LOW".

## IO-Link control devices

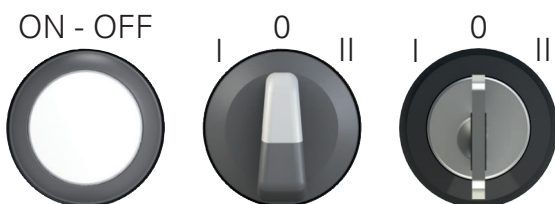

The following types of control devices can be connected via IO-Link:

- White spring-return button that can be illuminated with RGB LED;
- Two- or three-position selector switch with handle that can be illuminated with a white LED;
- White indicator light with RGB LED;
- Two- or three-position key selector;
- Emergency stop button with rotary or push-pull release;
- Hole blanking plug.

## Examples of available configurations

### Configuration with spring-return buttons only

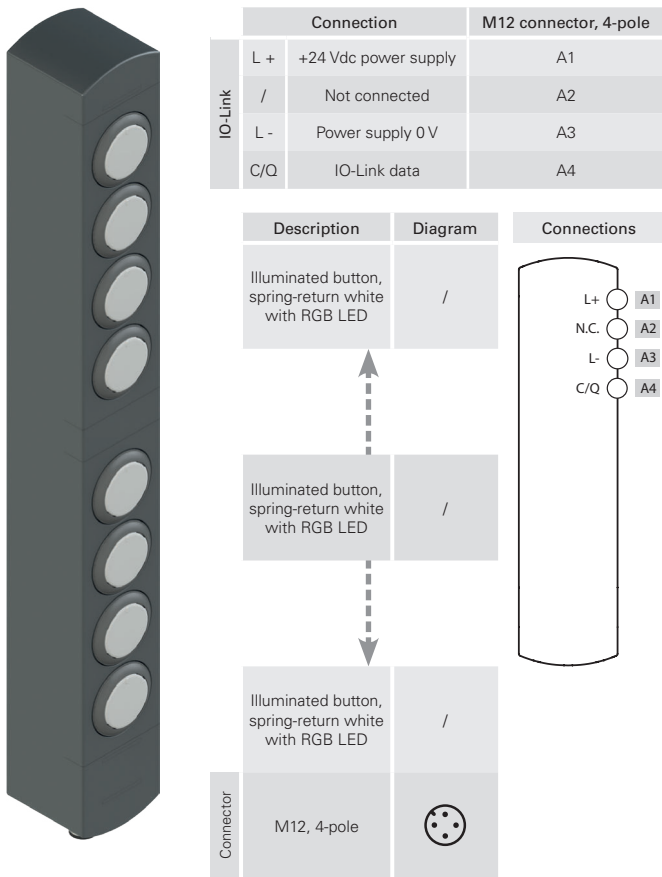

### Configuration with 1 emergency stop button and spring-return buttons

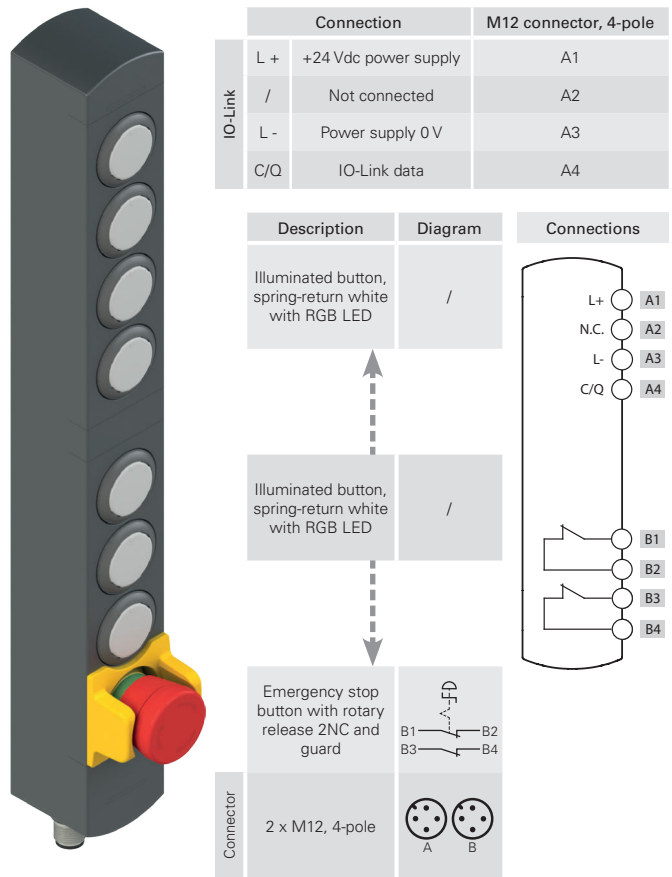

3 devices    4 devices    6 devices    7 devices    8 devices

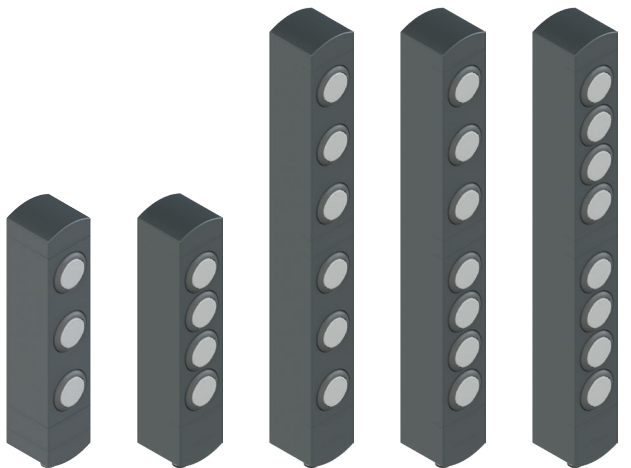

BN AC3EA08    BN AC4EA02    BN AC6EA09    BN AC7EA02    BN AC8EA02

3 devices    4 devices    6 devices    7 devices    8 devices

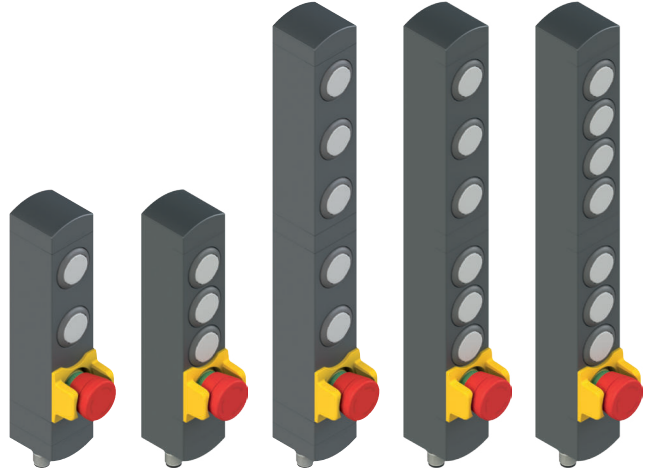

BN AC3EA09    BN AC4EA01    BN AC6EA07    BN AC7EA01    BN AC8EA01



## Examples of available configurations

### Configurations with 1 two-position selector, 1 emergency stop button and spring-return buttons

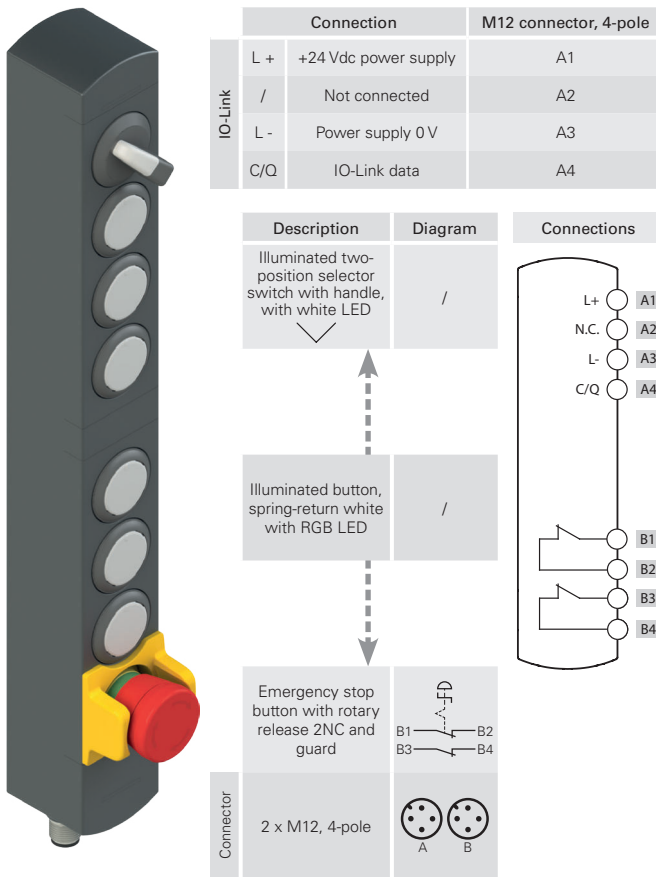

### Configurations with 1 two-position key selector, 1 emergency stop button and spring-return buttons

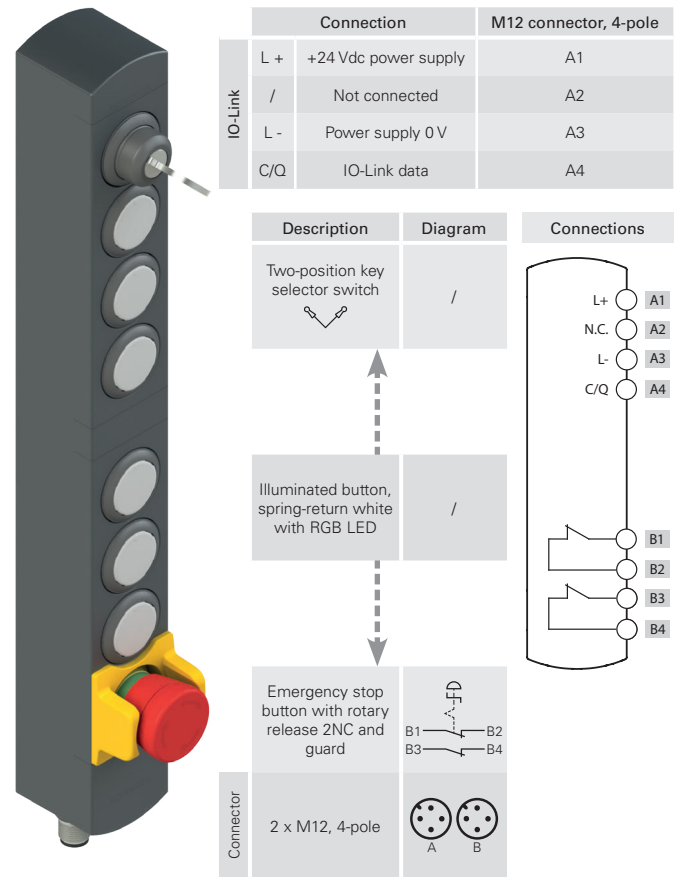

3 devices    4 devices    6 devices    7 devices    8 devices

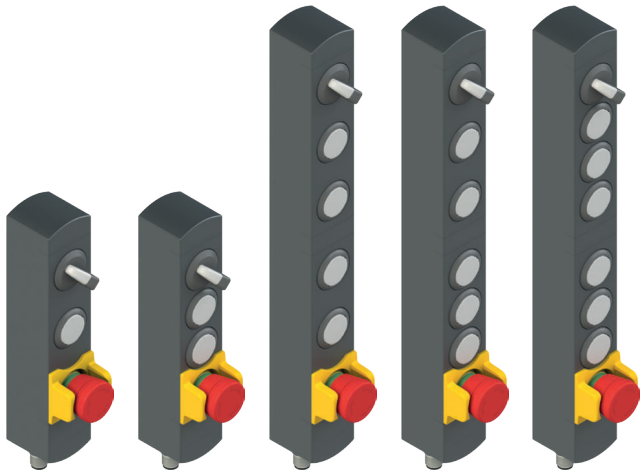

BN AC3EA10    BN AC4EA03    BN AC6EA13    BN AC7EA03    BN AC8EA03

3 devices    4 devices    6 devices    7 devices    8 devices

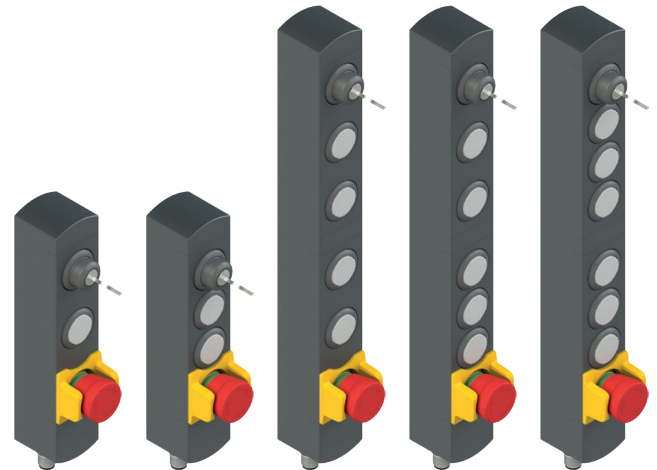

BN AC3EA16    BN AC4EA04    BN AC6EA14    BN AC7EA04    BN AC8EA04

## Examples of available configurations

### Configurations with 1 three-position selector, 1 emergency stop button and spring-return buttons

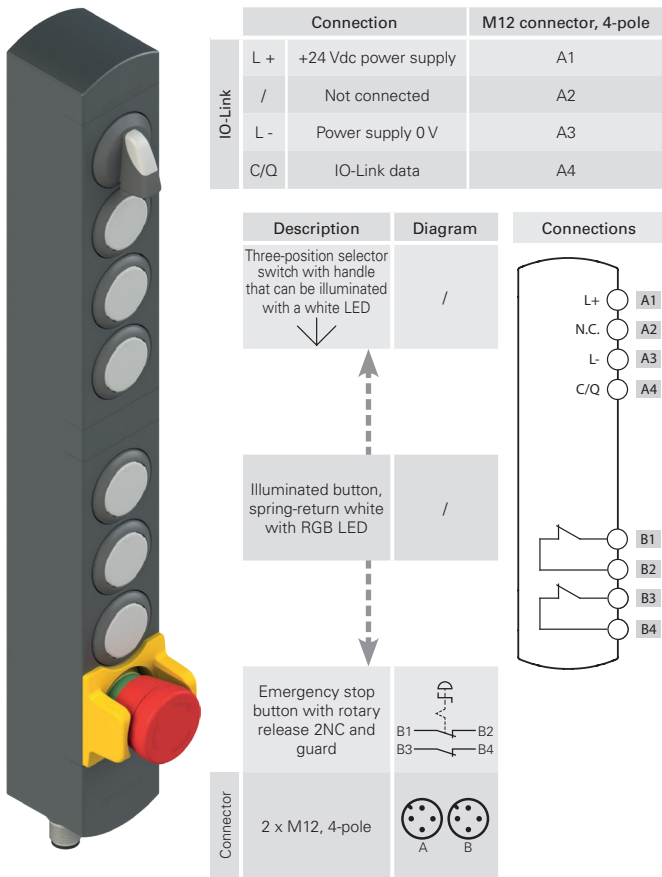

### Configurations with 1 two-position key selector, 1 emergency stop button and spring-return buttons

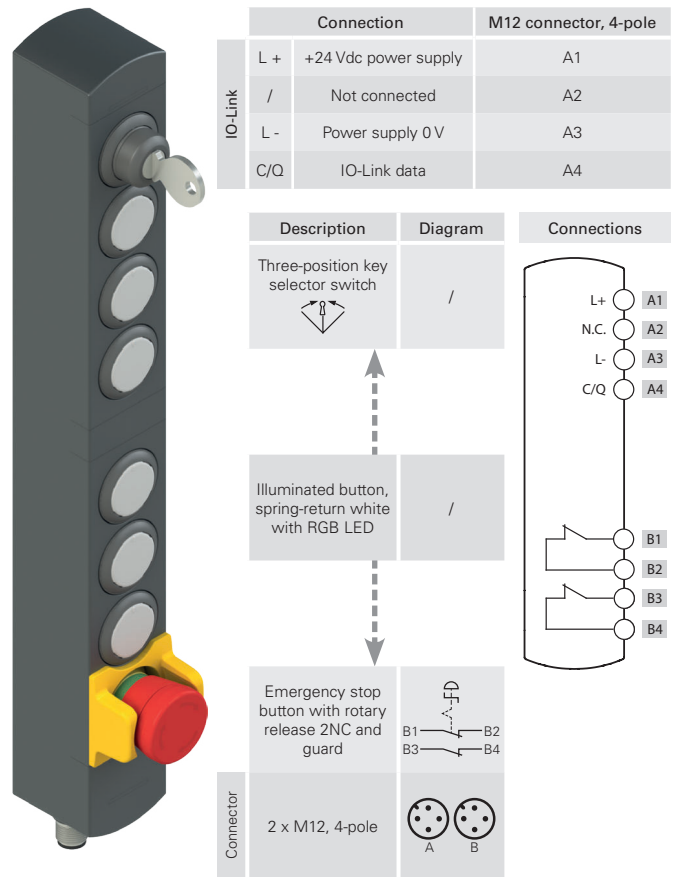

3 devices 4 devices 6 devices 7 devices 8 devices

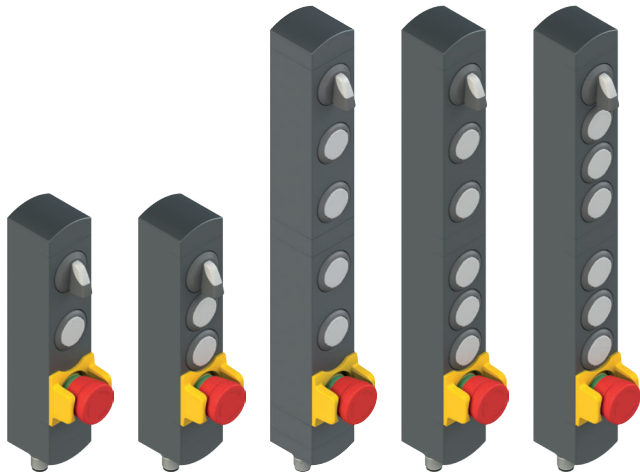

BN AC3EA17 BN AC4EA05 BN AC6EA08 BN AC7EA05 BN AC8EA05

3 devices 4 devices 6 devices 7 devices 8 devices

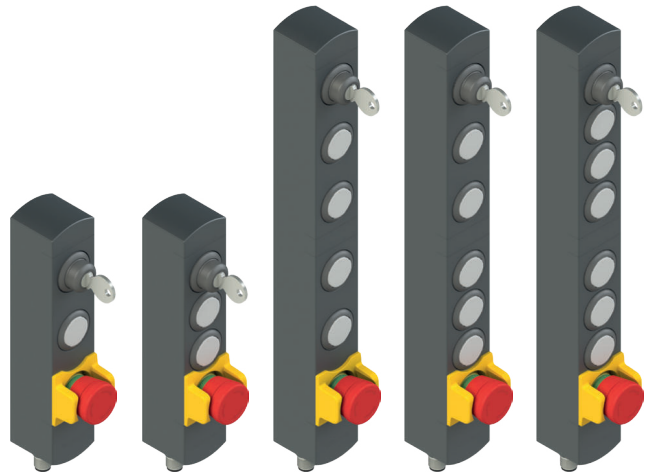

BN AC3EA18 BN AC4EA06 BN AC6EA10 BN AC7EA06 BN AC8EA06



# Examples of available configurations

## BN AC3EA13



Connection		M12 connector, 4-pole
L +	+24 Vdc power supply	A1
/	Not connected	A2
L -	Power supply 0 V	A3
C/Q	IO-Link data	A4

	Description	Diagram	Connections
Device 1	Illuminated button, spring-return white with RGB LED	/	
Device 2	Three-position selector switch with handle that can be illuminated with a white LED	/	
Device 3	Illuminated button, spring-return white with RGB LED	/	
Connector	M12, 4-pole		

## BN AC3EA14

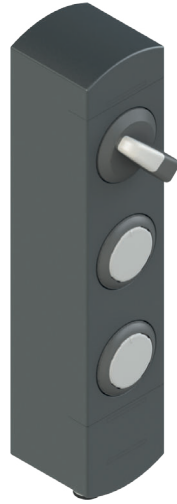

Connection		M12 connector, 4-pole
L +	+24 Vdc power supply	A1
/	Not connected	A2
L -	Power supply 0 V	A3
C/Q	IO-Link data	A4

	Description	Diagram	Connections
Device 1	Illuminated two-position selector switch with handle, with white LED	/	
Device 2	Illuminated button, spring-return white with RGB LED	/	
Device 3	Illuminated button, spring-return white with RGB LED	/	
Connector	M12, 4-pole		

For dimensional drawings see page 318 General Catalogue Safety Devices

## Lenses for VN NG-AC series buttons

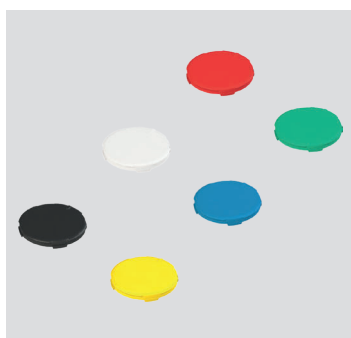

Lenses without engraving			
Article	Description	Colours	Pieces/package
VN NG-AC01	Lens for flush button, black, without engraving	●	10
VN NG-AC02	Lens for flush button, white, without engraving	○	10
VN NG-AC03	Lens for flush button, red, without engraving	●	10
VN NG-AC04	Lens for flush button, green, without engraving	●	10
VN NG-AC05	Lens for flush button, yellow, without engraving	●	10
VN NG-AC06	Lens for flush button, blue, without engraving	●	10
VN NG-ACA0	6 lenses for flush button without engraving, colours: black, white, red, green, yellow and blue	● ○ ● ● ● ● ●	1

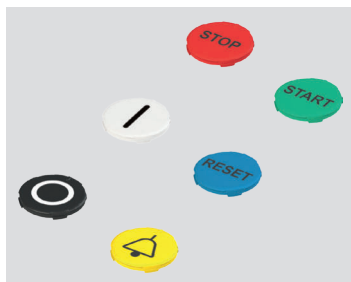

Lenses with engraving			
Article	Description	Colours	Pieces/package
VN NG-AC01-●●●●	Lens for flush button, black, with engraving	●	1
VN NG-AC02-●●●●	Lens for flush button, white, with engraving	○	1
VN NG-AC03-●●●●	Lens for flush button, red, with engraving	●	1
VN NG-AC04-●●●●	Lens for flush button, green, with engraving	●	1
VN NG-AC05-●●●●	Lens for flush button, yellow, with engraving	●	1
VN NG-AC06-●●●●	Lens for flush button, blue, with engraving	●	1

The black lens cannot be used with illuminated buttons.

**For ordering lenses for buttons with marking:** replace the dots ●●●● in the article codes with the marking code reported in the chapter Accessories on page 375 General Catalogue Safety Devices.

Example: white lens for flush button with "O" engraving. VN NG-AC02-●●●● → VN NG-AC02-L1

## How to replace lenses on buttons





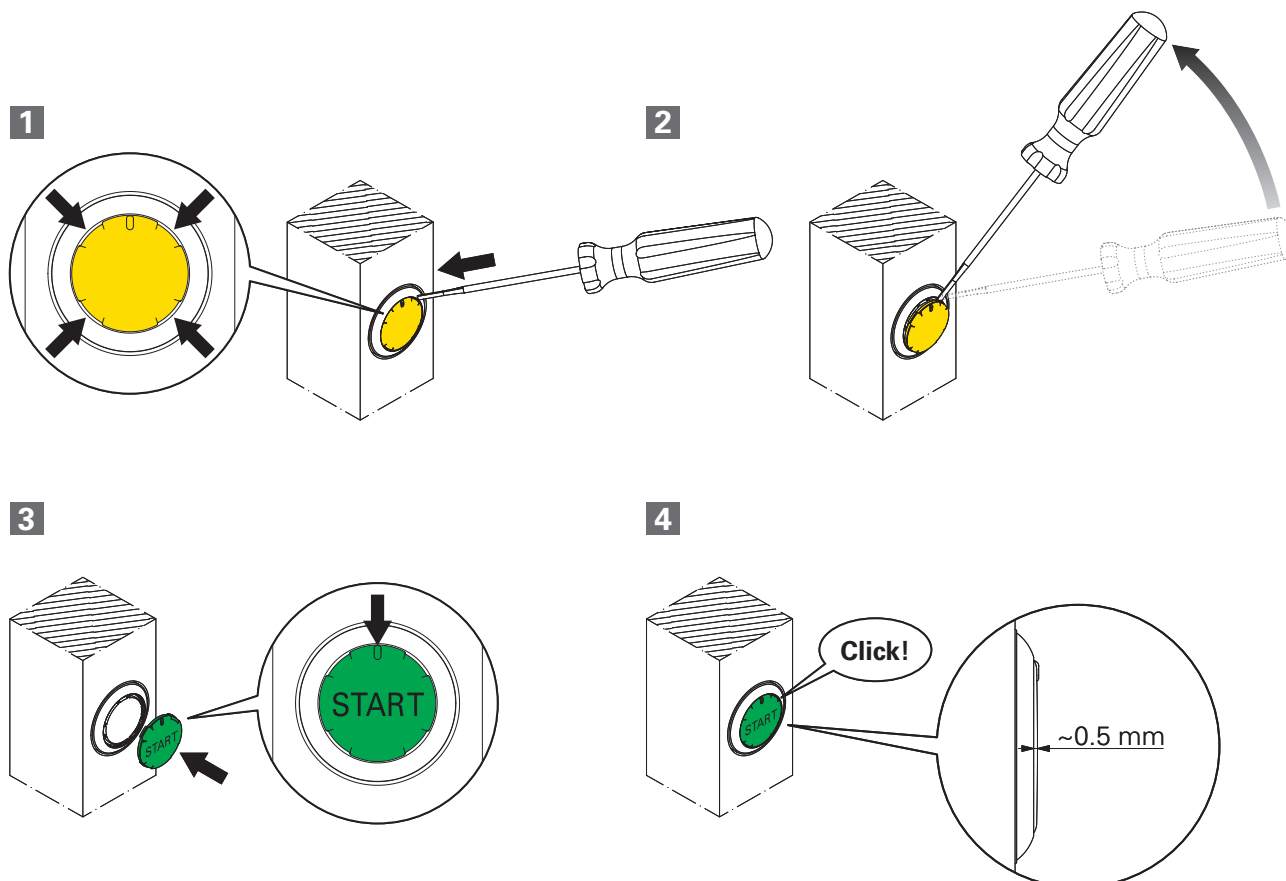









The buttons in the BN series control device units feature replaceable lenses. When replacing the lens on a button, work must be performed with care to avoid irreversibly damaging the button. It is therefore recommended to carefully follow the sequence of steps described below for replacing the button lenses, and to avoid applying excessive force:



- 1 Locate one of the four slots on the lens.
- 2 Insert a small flathead screwdriver or cutter into one of the slots and gently pry off the old lens. Be careful not to scratch or damage the button during this step.
- 3 Position the new lens parallel to the button, using the reference notch on the button to align the lens correctly. For proper lens installation, make sure the reference notch faces upwards, as shown in the figure, or turn the lens in 90° steps with respect to the vertical axis. If the notch is not positioned correctly, the lens will not fit into the button and could be damaged.
- 4 Press down lightly and evenly on the lens until you hear a "click" confirming that the lens has snapped into place. Once properly installed, the lens should be perfectly horizontal and slightly raised — about 0.5 mm — above the edge of the button.





## Spare part codes for control devices

	Description	Colour	Spare part number	Protrusion (x) mm
	Illuminated button, spring-return	● White	VN NG-AC28121	3
	Indicator light	● White	VN NG-AC26064	2.7
	Emergency stop button acc. to EN ISO 13850	● Red	VN NG-AC26052	26.4
	Rotary release	● Red	VN NG-AC26055	
	Push-pull release	● Red		
	Illuminated selector switch with handle with 2 or 3 positions and transparent lens for LED    	● Black	VN NG-AC26033	16.8
		● Black	VN NG-AC26030	
		● Black	VN NG-AC26034	
		● Black	VN NG-AC26031	
	Key selector switch, 2 or 3 positions    	● Black	VN NG-AC26043	39 (a) 14 (b)
		● Black	VN NG-AC26040	
		● Black	VN NG-AC26041	
	Closing cap	● Black	VN NG-AC26020	2.7
	Fixing key	● Black	VN NG-AC26080	/

**Legend:**  Maintained  Spring-return  Key extraction position (a) with key (b) without key

**The codes in the table refer exclusively to spare parts for the same control device. They should not be understood as codes for alternative devices to modify the configuration of controls on the BN IO-Link control device unit.**

### To order buttons with engraving:

add the engraving code indicated in the chapter Accessories on page 375 General Catalogue Safety Devices to the article codes.

Example: Spring-return button with "O" engraving.

VN NG-AC28121 → VN NG-AC28121-L1



General Catalogue  
Detection

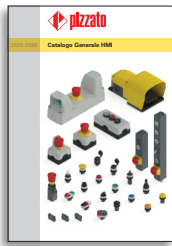

General Catalogue  
HMI



General Catalogue  
Safety Devices



General Catalogue  
- PLCs & Safety  
Modules



General Catalogue  
Lift



Website  
[www.pizzato.com](http://www.pizzato.com)



**Pizzato Elettrica s.r.l.** via Torino, 1 - 36063 Marostica (VI) Italy  
Phone: +39 0424 470 930  
E-mail: [info@pizzato.com](mailto:info@pizzato.com)  
Website: [www.pizzato.com](http://www.pizzato.com)

Any information or application example, connection diagrams included, described in this document are to be intended as purely descriptive. The choice and application of the products in conformity with the standards, in order to avoid damage to persons or goods, is the user's responsibility. The drawings and data contained in this document are not binding and we reserve the right, in order to improve the quality of our products, to modify them at any time without prior notice. All rights to the contents of this publication are reserved in accordance with current legislation on the protection of intellectual property. The reproduction, publication, distribution and modification, total or partial, of all or part of the original material contained therein (including, but not limited to, texts, images, graphics), whether on paper or in electronic form, are expressly prohibited without written permission from Pizzato Elettrica Srl. All rights reserved. © 2025 Copyright Pizzato Elettrica.

ZE FGL34B25-ENG



8 018851 684197