

Leuze



NOW SERVING

Food & Beverage Sensor Solutions

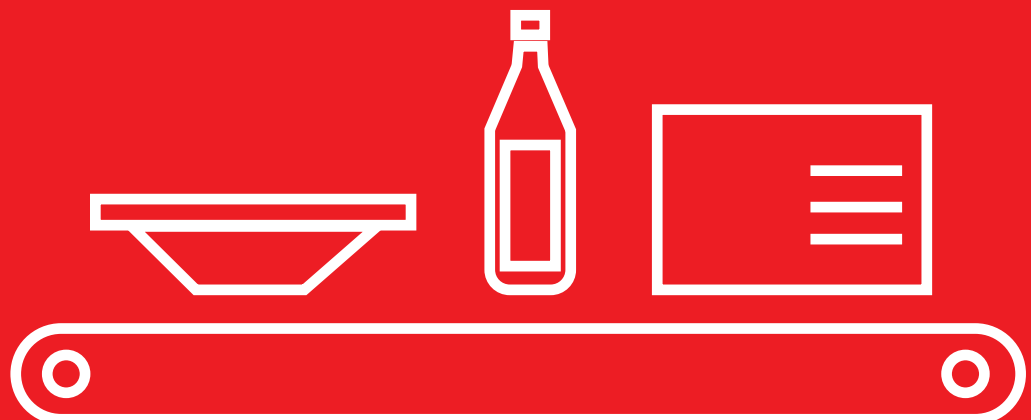

TABLE OF CONTENTS

Topics (click on topic - go straight to page)

Click  to return here

Page

<u>Sensor experts for automation technology</u>	3
<u>Principles of sensor detection</u>	4
<u>The right light source technology for every application</u>	5
<u>Harsh environments require perfectly matched solutions</u>	6 - 7
<u>Barcode Identification</u>	8
<u>Reflectors suited for food & beverage</u>	9
<u>Network and Connection Technology</u>	10
<u>Your benefits with IO-Link</u>	11
<u>Beverage Solutions - Beverage filling</u>	12 - 14
<u>Processing & Packaging Solutions - Meat, sausage and cheese</u>	15 - 18
<u>Processing & Packaging Solutions - Confectionery and bakery</u>	19 - 22
<u>Processing & Packaging Solutions - Dairy</u>	23 - 26
<u>Processing & Packaging Solutions - Labelling</u>	27 - 30
<u>Processing & Packaging Solutions - Carton and Container</u>	31 - 34
<u>Processing & Packaging Solutions - Palletizing</u>	35 - 37
<u>Hazardous Area Solutions</u>	38 - 41
<u>Our brands</u>	42

Sensor experts for automation technology



Application know-how

With over 60 years of experience, makes Leuze is an expert in innovative and efficient sensor solutions for the food and beverage industry.



Application know-how

Our aim is to ensure the long-term success of our customers in a constantly changing industry. This objective guides our every step.



Sensor usability

When we develop innovative high-tech solutions, we attach great importance to the easy operation and handling of our products.



Principles of sensor detection



A Leuze **through-beam sensor** is a high-performance photoelectric device consisting of two separate components: a transmitter (emitter) and a receiver. It operates by sending a continuous light beam (infrared, red light, or laser) from the transmitter directly to the receiver.



A Leuze **retro-reflective sensor** is a type of photoelectric sensor that detects objects by using a light beam reflected by a dedicated reflector. The sensor contains both the light emitter and receiver in a single housing and detects an object when it interrupts the light beam, blocking its return path to the receiver.



Leuze **diffuse sensors** are photoelectric devices that emit light and detect the presence of an object based on the light reflected back to the sensor from that object. They combine the transmitter and receiver into a single, compact housing, making them easy to install and ideal for applications with limited space. The majority also feature background suppression.

- › Throughbeam
- › Retro-reflective
- › Diffuse



The right light source technology for every application

Comparison Summary

In short, you've got four great options depending on your goal:



Standard LED: The reliable workhorse. It's the most budget-friendly, eye-safe, and durable choice for everyday sensing.



[Learn more](#)

Power PinPoint LED: The best of both worlds. It gives you the sharp, easy-to-aim dot of a laser with the safety and lower cost of a standard LED.



Laser: The precision expert. It's unbeatable for detecting tiny parts at long distances with incredible accuracy.



Infrared: Designed for the stringent, high-hygiene requirements of the food and beverage industry. Focusing on reliable detection in wash-down areas, direct food contact zones, and packaging lines.

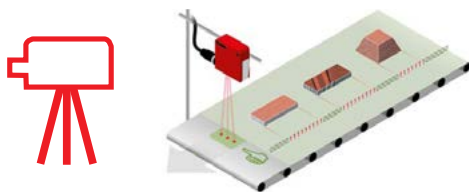

[Learn more](#)

Dynamic reference diffuse sensors: The **DRT 25C** dynamic reference diffuse sensor uses CAT technology. It recognizes flat or spherical-shaped products, transparent to high-gloss films or irregular shapes and contours. Easy and fast teaching of the sensor using the teach button, whereby the conveyor belt is used as a reference.

sales.au@leuze.com

- › Standard LED
- › Laser
- › Power PinPoint
- › Infrared
- › Dynamic reference



www.leuze.com.au

Harsh environments require perfectly matched solutions



- › Impermeability
- › Chemical requirements

Impermeability

Systems and the sensors installed in them are very often cleaned with high-pressure cleaners. Sensors are constantly exposed to moisture and humidity due to the high number of cleaning cycles.

- › Absolutely sealed housing
- › Diffusion-tight materials for optical covers & operating elements
- › Protection classes IP 67, IP 68 and IP 69K



Chemical requirements

Regular cleaning cycles with foam cleaners, disinfectants, alkaline or basic cleaners require resistant sensors.

- › ECOLAB certification
- › Diversey certification
- › Clean Proof+-certification



Harsh environments require perfectly matched solutions



- › Thermal requirements
- › Mechanical resistance

Thermal requirements

Strong temperature fluctuations between ambient temperature and cleaning temperature put a high load on sensors.

- › Sensor tests in the climate cabinet
- › Thermal shock tests (water bath hot-cold)
- › Steam jet test as part of the IP 69K approval
- › Temperature ranges from -40 °C to +70 °C



Mechanical resistance

In harsh production environments, sensors are exposed to dust, shavings, vibrations and other mechanical stresses.

- › Absolutely sealed housing
- › Robust housing: no additional housing necessary
- › Vibration and shock resistance

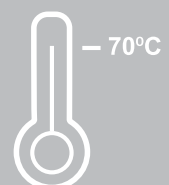
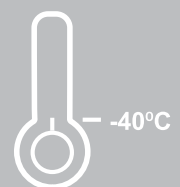

IP 69K

Barcode Identification



Perfect reading reliability

Successful detection of codes on partially destroyed, soiled or rotated bar code labels, even at a large angle of inclination, is possible thanks to the code reconstruction technology. Our code reconstruction technology functions so that the entire code can be reconstructed from individual, undamaged sections of code.

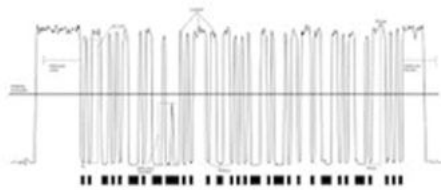

Reliable reading of bar codes with poor contrast

All our bar code readers operate with a scanning rate of 800-1000 scans/sec. After every scan, the electronics, such as filters and amplifiers, are adapted to the reception signal (adaptive signal adjustment). The contrast between bar and gap is thereby optimized.



Heated bar code reader product range

Through the integrated heating in the entire bar code reader product range, the electronics function reliably down to -35 degrees Celsius. This ensures that the optics do not fog or ice over.



- Stationary 1D bar code readers
- Stationary 1D / 2D code readers



[Learn more](#)

Reflectors suited for food & beverage

Reflectors

Sensors that operate according to the reflection principle need high-quality reflectors in order to function. Reflectors for all conceivable applications and environmental conditions are available to ensure an optimum detection result at all times.

Reflectors from the Extended segment are suitable for production areas with high humidity or high temperature differences.

Advanced segment



Ecolab (.P)
RED



Alcohol & H₂O₂ (.Chem)
Blue



Cleanproof+
Stainless steel



Solidchem (.SC)
Gold

Extended segment



Anti-fog (.AF)



UV coating (.UV)



Heat-resistant (.HT)

► For retro-reflective sensors



[Learn more](#)

Network and Connection Technology



- › Accessories
- › Cables

Cables and connectors

Sensors are only as good as the options for integrating them in your controls. For this reason, we offer you an extensive selection of accessories, including everything from the cables, to the connectors to the optional adapters. You can easily find the right parts for your application.



Connection and interconnection cables

M8 and **M12** connection cables for the connection of sensors in industrial environments

- › **3-, 4-, 5-, 8-, 12-, 17-pin cables**
- › Cables made of **PUR, PVC, TPE** and connectors with or without LED, angled or straight - high flexibility for many applications.



Y-distribution cables, user-configurable connectors and adapters

FAB cables - Food and Beverage

- › IP67 & IP69K rating
- › PVC coated



Your benefits with IO-Link



Quality assurance – Maximum process transparency

- › Access to all process and diagnostic data as well as device information is ensured.
- › The respective hardware and software version is available in the system documentation.
- › Built-in devices are identified via the serial number.
- › Recipe settings are managed via the PLC. The sensor is configured according to the requirements of the production order.



Diagnosis – Preventive maintenance

- › Precise diagnostic information enables preventive maintenance and optimization of the maintenance planning.
- › Data storage of the parameters is thereby automated.
- › The service technician can prepare for use by means of remote diagnostics.
- › The amount of work involved in troubleshooting is significantly reduced.



Commissioning – Device exchange made easy

- › Device types and application-specific designations are visible in the higher-level systems.
- › A new sensor or actuator is configured via the IO-Link master or by means of a function module.
- › Configuration is also possible with just a few mouse clicks using remote access.
- › Sensor settings can simply be copied and duplicated.



Cost savings – On all levels

- › Fast project planning/commissioning saves time and money.
- › Storage costs are reduced by standardizing the connection technology.
- › Independent of their complexity, there is a standardized, uniform interface for all sensors and actuators, regardless of whether switching, measuring, multi-channel binary or mixed signal.
- › As a complete system, IO-Link saves costs on all levels, from project planning and commissioning to repair and maintenance.

Technologies

› IO-Link

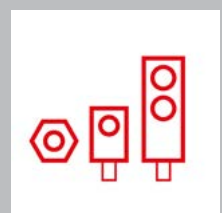

NOW SERVING

Beverage Solutions

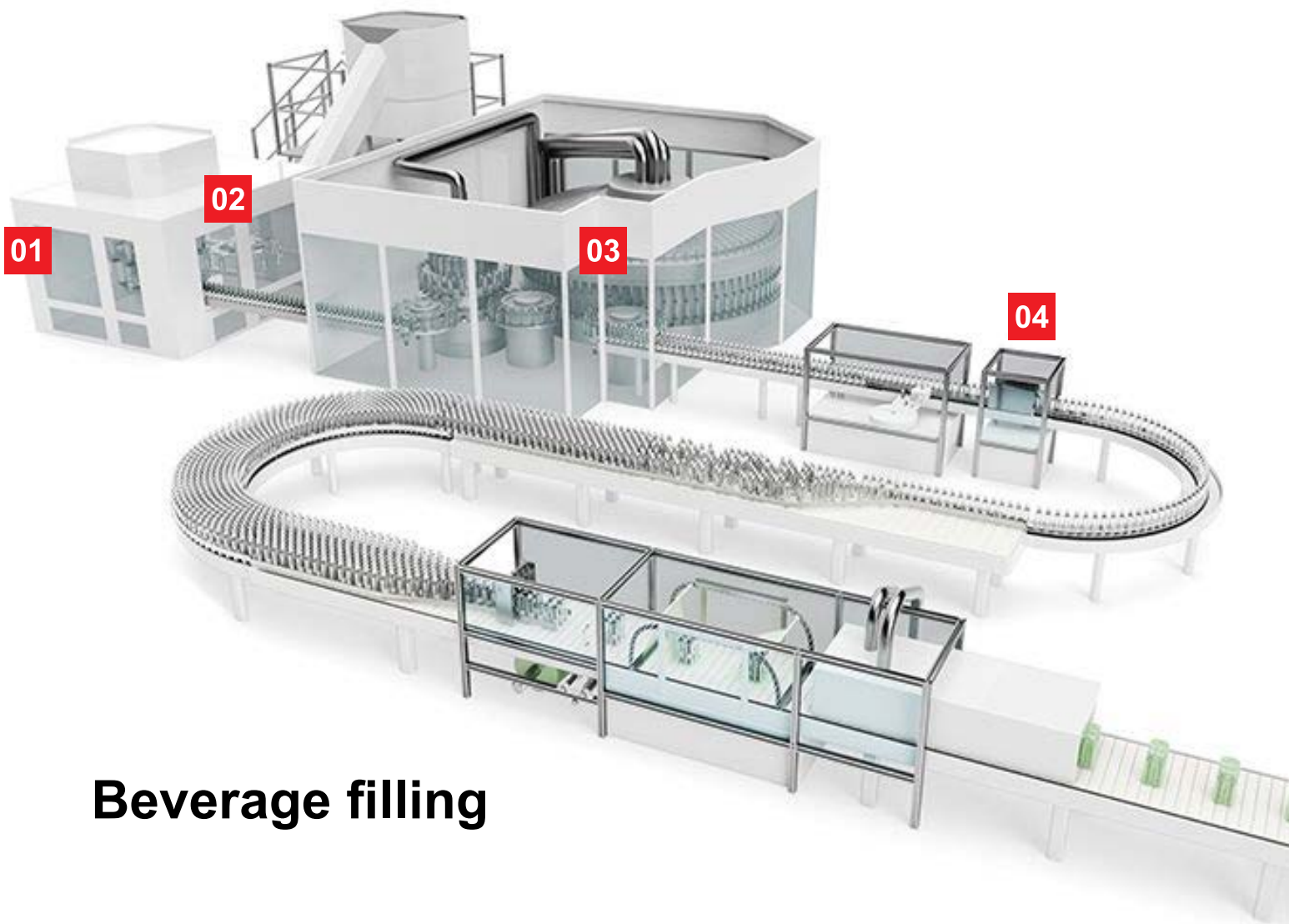

Beverage filling



Sensor solutions for beverage filling



Requirement:

PET bottles are blown from preforms in filling systems for plastic bottles. For this purpose, the transparent preform must be detected on the feed to the stretch blow molding machine.

Solution:

The retro-reflective photoelectric sensors of the **25C, 55C and 18B series** with autocollimation reliably detect transparent objects. They are ideally suited for detection tasks on stretch blow molding machines, as they can compensate for temperature fluctuations and contamination.

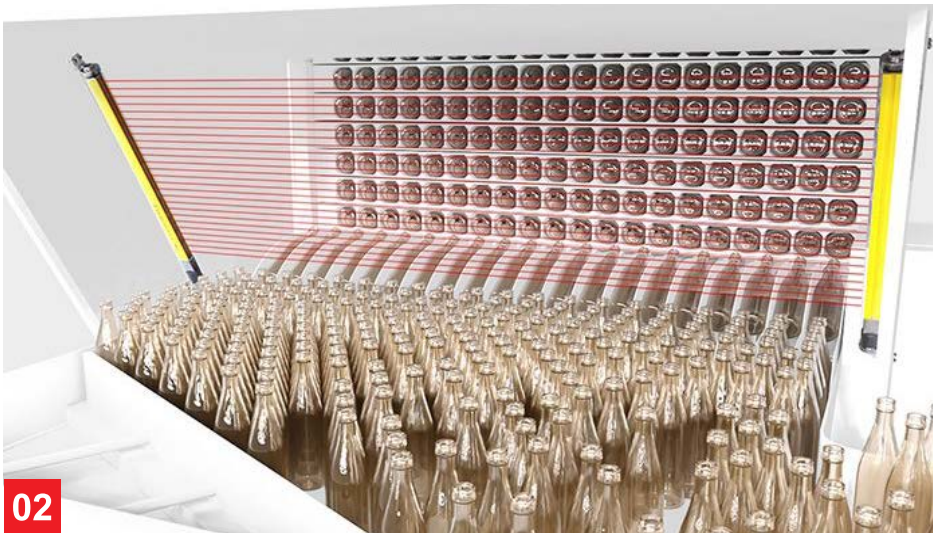

Requirement:

Machine openings ensure good accessibility to the system. The points of operation must be secured with optical protective devices during operation. Even in harsh environments, such as bottle cleaning machines.

Solution:

The **MLC 500** safety light curtains are a flexible solution for guarding machine openings. They are available with a resolution from 14 mm and in protective field lengths up to 3,000 mm. For demanding environments, the models with a degree of protection IP 69K in an encapsulated protection tube are suitable.

sales.au@leuze.com

Areas of application

1. Detection of PET bottles
2. Guarding of points of operation during bottle cleaning



25C series

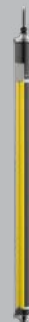

MLC - Safety light curtain

www.leuze.com.au

Sensor solutions for beverage filling



Requirement:

Bottle filling is characterized by very high speeds. For a smooth process, it must be ensured prior to filling that all positions of the transfer star wheel is occupied with bottles.

Solution:

The **HT55C** diffuse sensor with background suppression reliably detects bottles during the filling process and does so without reflectors. ECOLAB certification and the enhanced Leuze cleaning agent long-term test CleanProof+ ensure the functionality of the sensor in wet areas and during intensive cleaning processes.



Requirement:

After the bottles have been sealed, the fit of the cap is checked at a test station. Only correctly fitted caps ensure a proper sealing of the bottle.

Solution:

With its extensive tool set, the **IVS 1148i** Simple Vision sensor can determine whether the bottle cap is sealed correctly. A user-friendly, graphical interface ensures fast setup and smooth operation of the sensor.

Areas of application

3. Bottle detection in transfer star

4. Bottle cap control



[55C series](#)



[IVS 1148i](#)

Leuze

NOW SERVING

Processing & Packaging Solutions

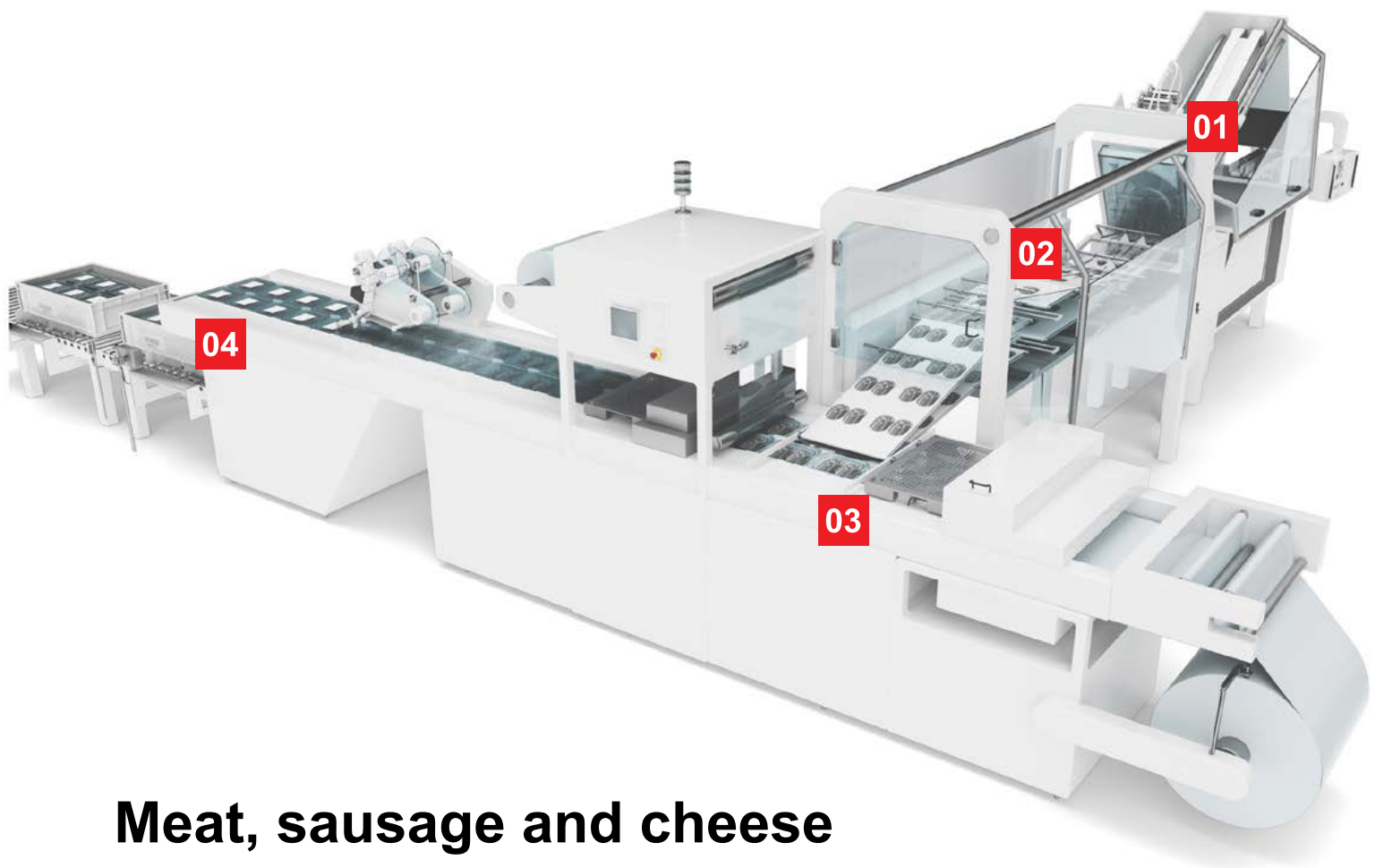

Meat, sausage and cheese



Sensor solutions for food processing

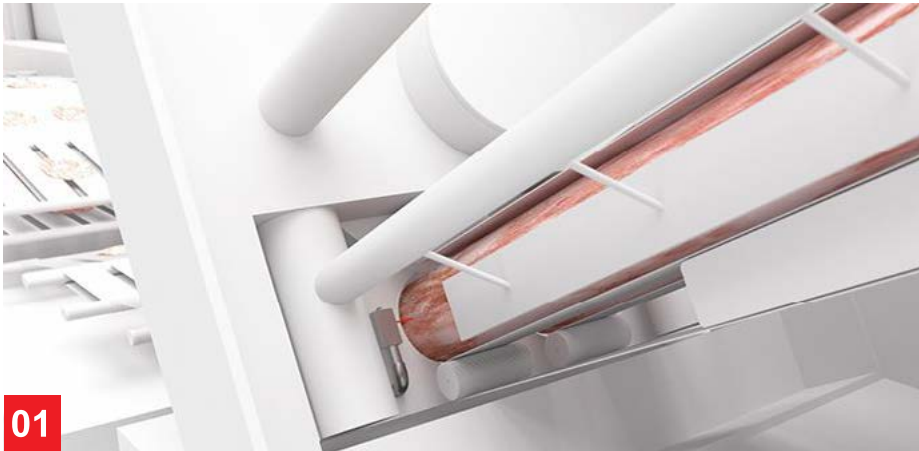

Requirement:

In the food industry, sausage or cheese is delivered in large bars and thinly sliced in a cutting machine. The product must be reliably detected in the infeed of the machine so that the gripper can uniformly push the material towards the knife and all cut slices have the required thickness.

Solution:

The **HT53C.S diffuse sensor** in hygienic design monitors the product infeed at the cutting machine. A particularly small light spot ensures very good performance, especially with objects with colored structure. Background suppression of the sensor enables reliable color-independent product detection.



NEW 04/2026 TOF technology meets hygiene: laser distance diffuse sensors for demanding applications

The **ODT 53CL1-2M** and **ODT 55CL1-2M laser diffuse sensors** expand our range of distance sensors for long operating ranges.

The **ODT 5xCL1-2M diffuse sensors** have been developed for applications in demanding environments where the presence of objects is to be detected and measurement values are to be output via IO-Link over long distances.

sales.au@leuze.com

Areas of application

1. Monitoring of the product infeed
2. Detection of cut goods



[53C series](#)

www.leuze.com.au

Sensor solutions for food processing



Requirement:

Moving protective devices such as doors and flaps protect the operator from hazards. In the so-called white areas, safety switches with locking device in a hygienic design are required.

Solution:

The **Pizzato safety switches with locking device** keep safety doors locked until access is released by an electric signal. The series includes standard designs, devices with integrated operational controls as well as with RFID-coded actuators. Technopolymer housings with smooth surfaces are suitable for hygiene-sensitive areas.

NX_Ecolab Series



The **NX series safety switch from Pizzato** is based on RFID technology, bistable operation, three actuator entries and robust metal head guarantee the highest safety levels PL e and SIL 3.

sales.au@leuze.com

Areas of application

- › **Monitoring of doors and flaps with locking device**

Distributor for

- › **Pizzato safety products**



[Pizzato safety switches](#)

www.leuze-australia.com.au

Sensor solutions for food processing

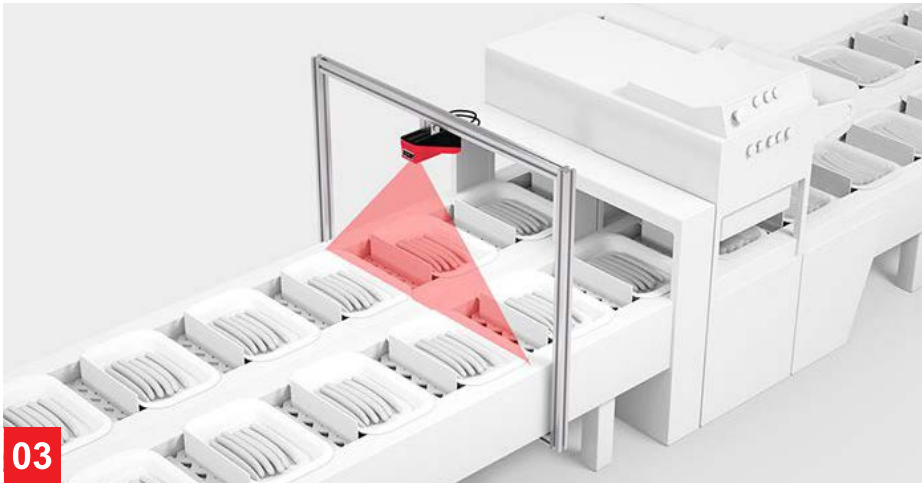

Requirement:

Before the trays are sealed in the sealing machine, it must be checked to determine whether all trays are filled. Unfilled and overfilled containers must be discharged. The control is carried out by sensors mounted above the conveyor.

Solution:

The **LRS 36 light section sensor** uses a projected laser line to detect the filling status of the individual trays. The sensor provides several switching outputs and process data for the control.



Requirement:

After products have been packaged in thermoformed trays, for example, the front edge must be reliably detected from above, even in single or multiple track systems. Different heights of the trays can pose a challenge for the sensor system used.

Solution:

The **DRT 25C dynamic reference diffuse sensor** sets the conveyor belt as a reference and thus allows for reliable detection of the front leading edges of the object on the belt - independent of the colors or heights of the products. Light spots arranged horizontal to the transport direction also detect products with gaps.

Areas of application

- › Filling-level inspection
- › Detection of thermoformed trays



[LRS 36](#)



[DRT 25C](#)

Leuze

NOW SERVING

Processing & Packaging Solutions



Confectionery and bakery



Sensor solutions for food processing

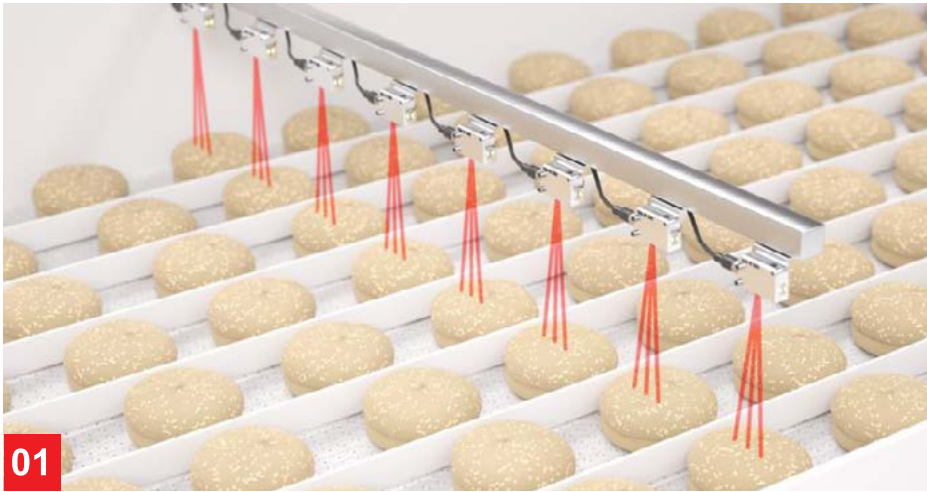

Requirement:

In the food industry, several conveyor belts are arranged close together, with detection taking place from above. Sensors mounted above open food products must meet stringent requirements, which is why components approved for food contact should be used.

Solution:

The **DRT35C dynamic reference sensor** detects any products by using the conveyor belt as a reference. The sensor, with a high-quality stainless steel housing with smooth surfaces (typical value $\leq 0.8 \text{ Ra}$), is the perfect solution for mounting above open food. Thanks to the stainless steel housing, no additional sensor enclosure is required.



Requirement:

In confectionery production, molds are used to manufacture or mold products. In the process, the first step is to identify and verify the empty mold.

Solution:

The universal compact **DCR 200i** code reader reliably captures 1D or 2D codes. It is available with a stainless steel housing for use in food processing. For larger distances to the empty mold, the high-performance **DCR 1048i** Simple Vision sensor is suitable.

sales.au@leuze.com

Areas of application

1. Detection of unpackaged products on conveyor belts
2. Identification of empty molds



DRT 35C



DCR 200i

www.leuze.com.au

Sensor solutions for food processing

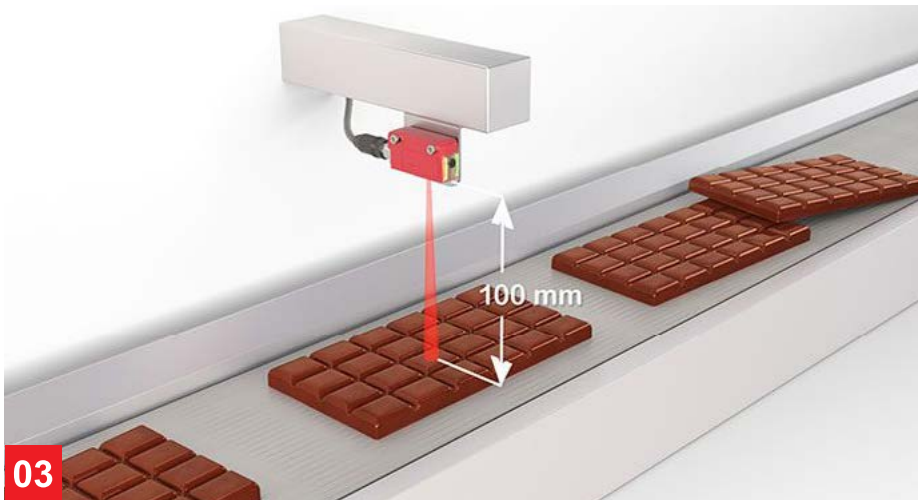

Requirement:

For further processing in a horizontal packaging machine, it must be checked that the manufactured products (e.g. chocolate bars) run separately on the conveyor belt. For this purpose, monitoring is performed to determine whether the defined product height or overlapping objects is maintained.

Solution:

The **ODT 3C sensor** is installed above the conveyor belt, looking down at the products. It detects the objects (switching sensor function) and simultaneously measures their height (measuring sensor function). This ensures that products run separately on the conveyor belt. The measurement data is output via the **IO-Link interface** of the sensor.

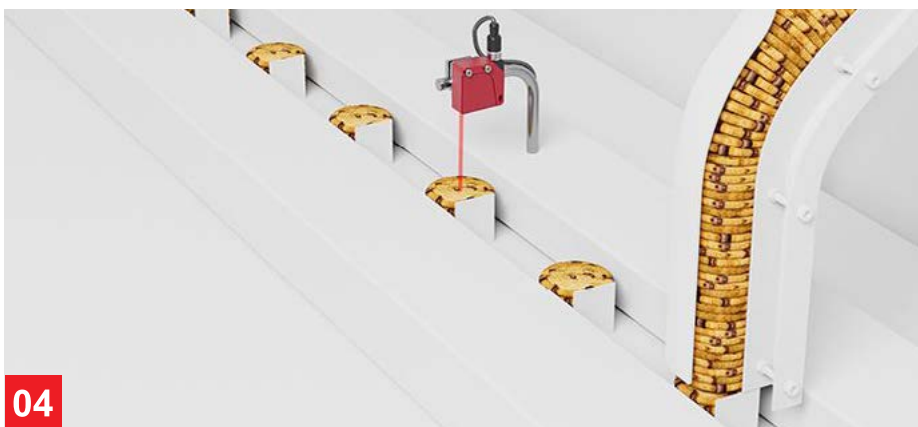

Requirement:

If several flat products are stacked on top of each other, the stack height must be monitored so as not to impair the subsequent packaging process. At the same time, the number of stacked products can be controlled.

Solution:

For different measurement ranges and resolutions, the **ODS 9 measuring distance sensors** are suitable for fill-level monitoring. Due to the parameterizable analog current or voltage output and the **IO-Link interface**, they can be easily adapted to the control environment used.

Areas of application

3. Quality and object height monitoring

4. Product height monitoring



[ODT 3C](#)



[ODS 9](#)

Sensor solutions for food processing



Requirement:

Products are packed in packaging films in horizontal packaging machines. Sensors must detect the printed contrast markers and thus control the precise cutting process. Common challenges are the limited installation space and the frequent format changeovers due to films and contrast markers of different colors.

Solution:

The compact **KRT 3C contrast sensor** is available in three models: the flexible version with RGB LEDs, a universal version with white light, and a version for larger distances with laser-generated red light. The sensors can be taught via the **integrated teach button, IO-Link, or cable**.



KRT 18B contrast sensor with white-light

The **KRT 18B series contrast sensors** combine ease-of-use thanks to permanent signal indicators with high performance. Models in **multicolor (RGB)** or **white light (W)** offer optimum performance for marker detection on colorfully printed or glossy films.

Free selection of adjustment method: intuitively using removable potentiometers, quickly and precisely by means of teach buttons. Also of course remotely through teach via cable or IO-Link. Small, compact housing made of nickel-plated metal, IP67 and IP69K and ECOLAB.

sales.au@leuze.com

Areas of application

5. Detection of cut marks in film feed



[KRT 3C](#)



[KRT 18B](#)

www.leuze.com.au

Leuze

NOW SERVING

Processing & Packaging Solutions

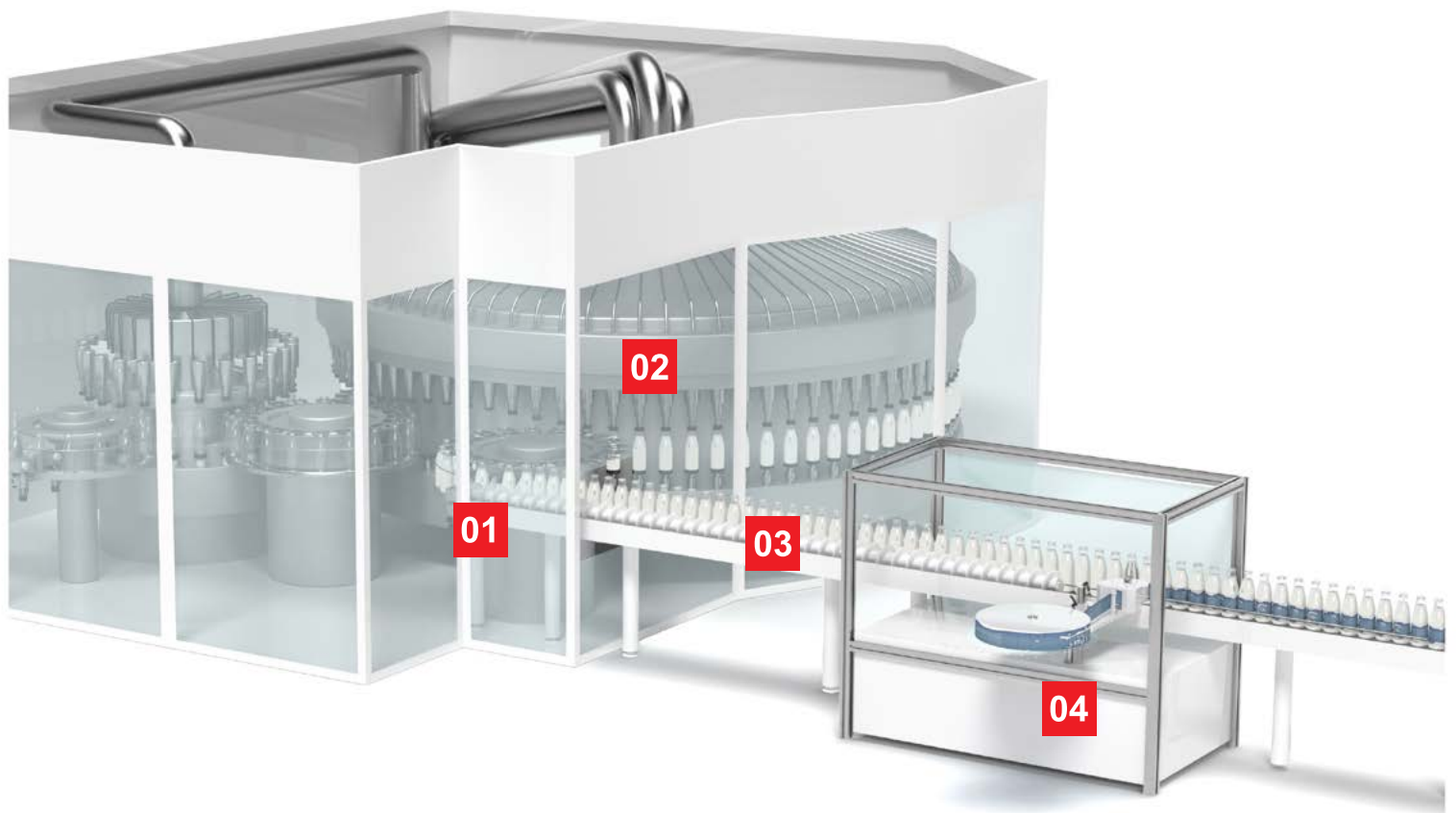

Dairy



Sensor solutions for dairy packaging



Requirement:

In a filling system for yogurt jars or milk bottles, their position on the conveyor belt is to be reliably detected. Sensors for this application must withstand the demanding environmental conditions in the clean zone.

Solution:

The **PRK 55C retro-reflective photoelectric sensor** reliably detects transparent containers. The sensitivity can be set via a teach button. An optional tracking function automatically compensates for soiling on the reflector or sensor. The robust stainless steel housing in wash-down design has a degree of protection IP 69K.

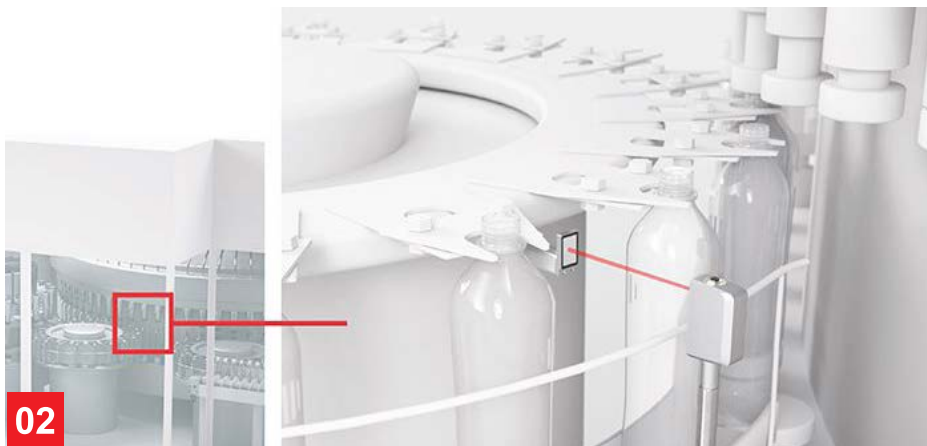

Requirement:

In a bottling plant, beverages are bottled under aseptic conditions. The aseptic system regularly undergoes CIP (Clean in Place) cleaning cycles. Both the machines and all components must be optimized for this demanding hygienic application.

Solution:

The **PRK33C.PPTT3 photoelectric reflex switch** has been developed for the detection of transparent objects. The stainless steel sensor in hygienic design is an optimal choice for the detection of transparent bottles in aseptic filling and for other sterile production environments in the food and pharmaceutical industry. A particularly smooth housing without mounting holes prevents deposits. The sensor is mounted gas-tight using a mounting spigot.

sales.au@leuze.com

Areas of application

1. Container detection during transport
2. Filling level measurement



[PRK 55C](#)



[PRK 33C](#)

www.leuze.com.au

Sensor solutions for dairy packaging



Requirement:

The flow of goods is to be detected for transport control of a single-lane transport line of soft packaging. Optical sensors can detect even the smallest gaps between soft packages.

Solution:

The **PRK 55CL retro-reflective photoelectric sensor** with a small laser light spot is suitable for detecting small gaps. A matching reflector in the MTKS.5 stainless steel housing is available in several sizes. The sensor and reflector are ECOLAB-certified.



Requirement:

If identical products are combined into larger packages, they must be reliably detected independent of shape, color and surface. High-performance sensors are an important prerequisite for a high degree of automation.

Solution:

The **PRK 46C retro-reflective photoelectric sensors** are suitable for detecting outer packaging thanks to their high function reserve and good optical properties. The sensors have a degree of protection IP 69K and ECOLAB certification. Other models with different light spot geometries are available.

sales.au@leuze.com

Areas of application

3. Detection of soft packaging
4. Detection of outer packaging



PRK 55C



PRK 46C

Sensor solutions



Requirement:

Food and beverage industries demand routine wash down and sterilization of machinery that can often wreak havoc on industrial equipment. Add to that the need to be flexible and be able to adapt to a new production line or another range of products, and it's quickly evident that a fast changeover to a new product can provide a competitive advantage.

Solution:

Our innovative IP69K stainless steel rotary encoder and various photo-electric and ultrasonic sensors use the latest innovative technologies. These products are designed to eliminate common machine failures while improving equipment operation and reliability.



TR Quality makes everything taste better

Key Products for Food & Beverage:

- **Hygienic Rotary Encoders:** Absolute and incremental encoders (e.g., Stainless Steel) with IP69K protection for harsh, washdown environments.
- **Compact Drives:** Intelligent units combining encoders and motors for, automated positioning in production lines.
- **Linear Encoders:** For precise linear movement control.

These products are specifically built to resist corrosion and prevent debris accumulation during cleaning, ensuring compliance with strict safety standards.

Areas of application

- Packaging
- Processing
- Conveyor systems
- Safety compliance
- Monitoring

Distributor for

- **TR-electronic encoders and drives**



Leuze

NOW SERVING

Processing & Packaging Solutions

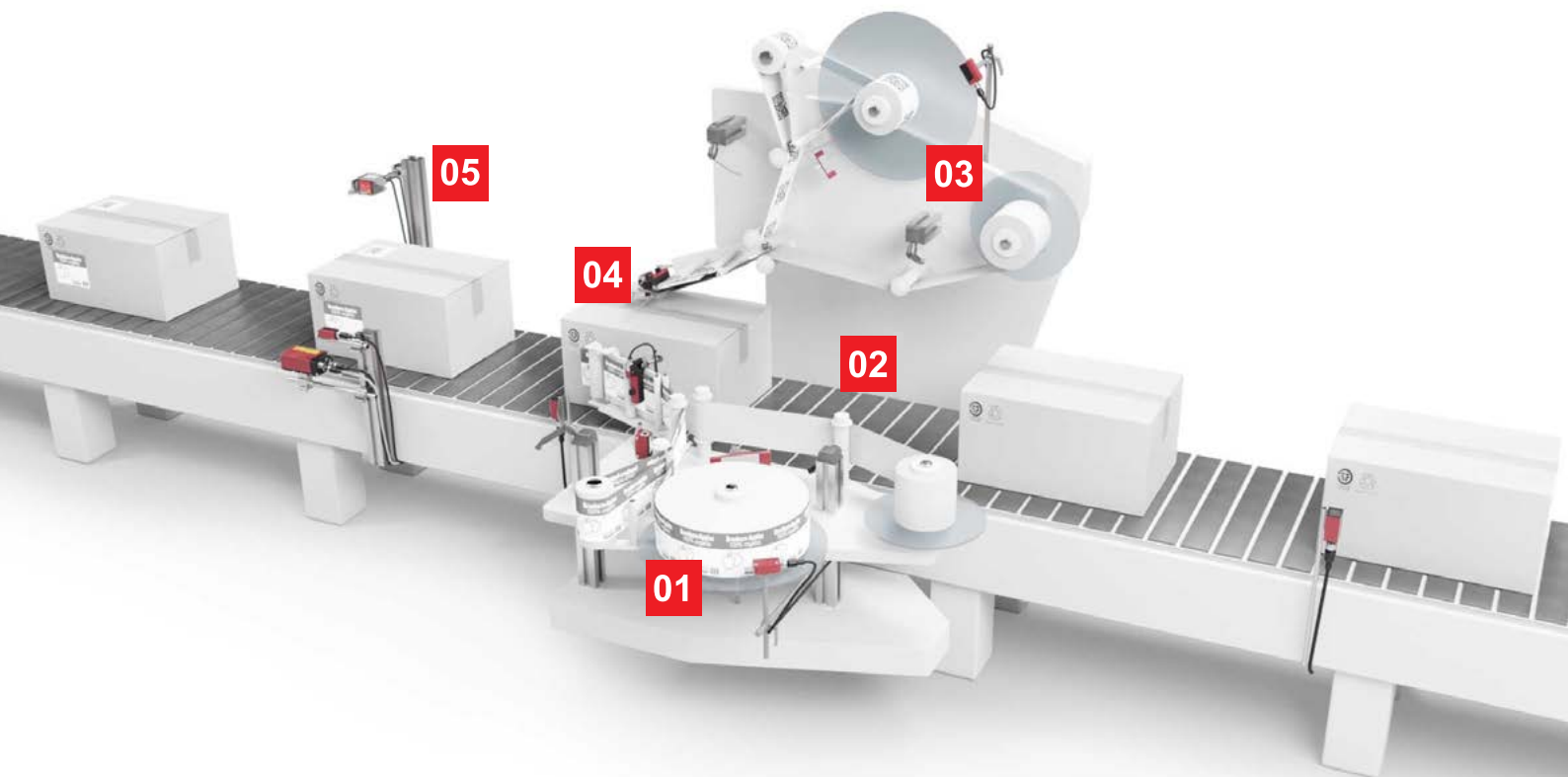

Labeling



Sensor solutions for labeling



Requirement:

In labelers with a longer tape path, e.g. as a buffer between the roll and the dispenser, it is necessary to detect a possible tape tear.

Solution:

Diffuse sensors with particularly long light-spot geometry, such as the **HT3C.XL**, are suitable for monitoring the label tape. The sensor tolerates fluctuations and reliably detects only the actual tape tear. The compact design makes it easy to integrate the sensor.



Requirement:

Labels should be applied at specified positions on the bottle. In addition, the alignment of the bottle must be detected and corrected on the basis of small features, such as embossing lugs or the joining seam. In compact machines, there is usually little installation space available for sensor systems.

Solution:

The **GF glass fiber optics** with different optical outlets and the **LV 463 amplifiers** are very suitable for checking the bottle alignment. Fiber optic sensors are particularly sophisticated and powerful at the same time. The sensors have an IO-Link interface and an optional analog output.

sales.au@leuze.com

Areas of application

1. Monitoring of label tape
2. Checking of bottle alignment



HT 3C



Fiber optic sensors

www.leuze.com.au

Sensor solutions for labeling



Areas of application

3. Detection of transparent labels



Requirement:

For a position-accurate dispensing process of labels onto products or objects, the labels must be detected on the carrier tape. Transparent, partially transparent or metallized labels in different shapes are also to be detected precisely. The sensor should be easy to set for all types of labels.

Solution:

The **GSU12**, **GSU14E** and **IGSU14E** ultrasonic fork sensors detect transparent and partially transparent labels. The **GSX14E sensor** combines an ultrasonic and an optical detection system in one housing and can even process labels made of inhomogeneous cavitated BOPP material. The IO-Link interface simplifies the setting.

Which sensor is right for which label-carrier combination?

	Label Base material	Non-Transparent	Transparent	Metalized	Booklet	Cavitated BOPP
 Optical GS63B, GS61	Not Transparent	●		●	●	●
	Transparent	●		●	●	●
 Ultrasonic GSU12, (I)GSU14E	Not Transparent	●	●	●	●	
	Transparent	●	●	●	●	
 Ultrasonic & Optical GSX14E	Non Transparent	●	●	●	●	●
	Transparent	●	●	●	●	●



GSX 14E

Sensor solutions for labeling



Requirement:

Non-transparent labels should be dispensed on packaging. To do this, the gap between two labels on the carrier tape must be precisely detected. The sensor should also reliably detect labels with complex shapes in order to avoid inaccurate dispensing or machine downtimes.

Solution:

The **GS61 and GS63B** optical fork sensors reliably detect the complete range of non-transparent labels. The sensor can be adjusted either with a potentiometer or via a teach function. The slimline design of the lower fork enables installation directly at the dispensing edge.



Requirement:

On containers such as bottles or vials, it is often necessary to check that the paper labels are on the objects after the dispensing process. The labels should be detected independently of the bottle or filling.

Solution:

The **LRT 8 luminescence sensor** detects paper labels reliably on different objects, even at large distances. Luminescence sensors detect both visible as well as invisible luminescent markings.

Areas of application

4. Detection of non-transparent labels
5. Label presence detection



[GS 61/GS 63B](#)



[LRT 8](#)

Leuze

NOW SERVING

Processing & Packaging Solutions

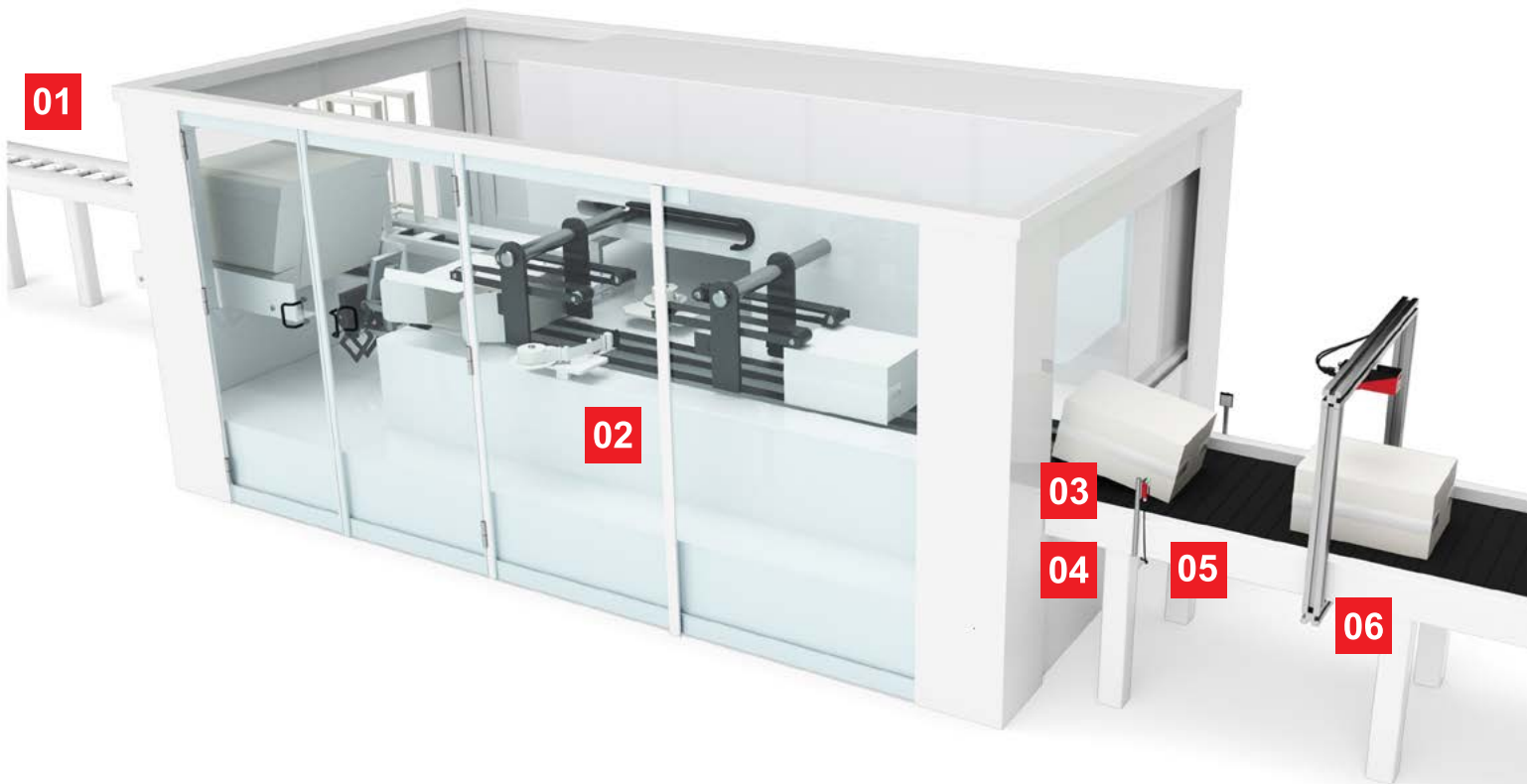

Carton and container



Sensor solutions for carton and container packaging

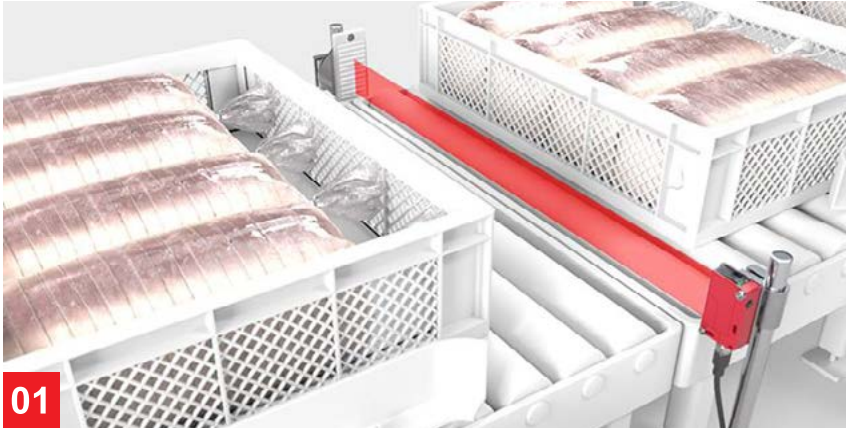

Requirement:

Food is transported in plastic baskets between individual process steps. Sensors with suitable light-spot geometry are required for reliable detection of the baskets. Small interruptions, different colors, surfaces or container heights must not impair detection.

Solution:

The **RK46C.DXL VarOS light-band sensor** reliably detects objects with a 45 mm wide light-band. Detection takes place at any point within the light-band. Irregular front edges or interrupted containers, e.g. baskets, are thereby reliably detected. Standard reflectors can be used on the opposite side.



Requirement:

In the feed of a sealing machine, the completeness and the presence of several products is to be detected. Incomplete packages are to be discharged.

Solution:

The **IVS 108 Simple Vision sensor** detects missing products via reference images or/and via pattern matching. With integrated software tools, the sensor can be easily and quickly adapted to different inspection tasks.

Areas of application

1. Detection of objects with openings
2. Monitoring completeness



RK 46C



IVS 108i

Sensor solutions for carton and container packaging



Requirement:

Machine areas or conveyor belt sections are equipped with doors to allow maintenance and cleaning work. During operation, the doors must remain closed and must be monitored for safety reasons.

Solution:

TL 305 signal tower lights in combination with an RD 800 safety proximity sensor monitor opening of the doors. If a door is opened, a visual and/or acoustic warning is output.

Alternately, the **Qlight STG series tower lights** are available. We are the distributors for **Qlight here in Australia**.



Requirement:

For access to individual machine areas, machines are equipped with doors and flaps, e.g. to allow magazines to be changed or areas to be cleaned. While the machine is in operation, these doors and flaps must remain closed and monitored for safety-related reasons.

Solution:

The **RD 800 safety proximity sensors** monitor doors & flaps with their RFID-coded actuators providing maximum protection against tampering. With an IP 69K protection rating and operating temperature up to 70 °C, they can be used for a wide variety of applications. OSSD outputs and performance level PL e ensure easy integration.

Areas of application

3. Access control for systems and conveyor belts

4. Monitoring of safety doors

Distributor for

› Qlight signal tower lights and beacons



[TL 305](#)



[Qlight tower lights](#)



[RD 800](#)

Sensor solutions for carton and container packaging



Requirement:

Objects are to be detected in a packaging film to avoid collision with the weld bar. The objects to be packed can have any shape.

Solution:

The **CML 730PS measuring light curtains** are developed for the detection of objects in film. With the aid of the power setting, different packaging films can be transilluminated in one or more layers and the products inside can be detected.

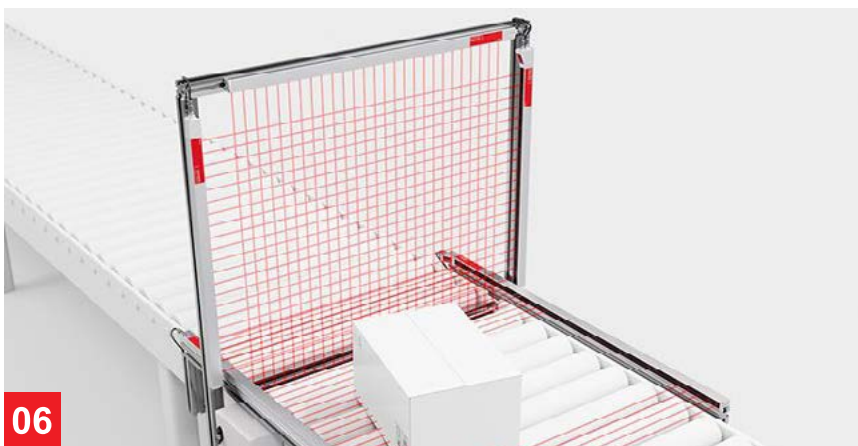

Requirement:

In order to correctly allocate shipping cartons, the volume is to be determined. For this purpose, the dimension of the shipping cartons passing through must be measured in all three dimensions.

Solution:

As objects pass through, the **CMS 700i contour measurement system** determines their height, width, length, orientation angle and position relative to the edge of the conveyor. The complete system contains all components required for installation and operation. Communication is Ethernet-based via PROFINET and TCP/IP.

sales.au@leuze.com

Areas of application

5. Detection of objects in film
6. Shipping carton volume measurement



CML 700i



CMS 700i

www.leuze.com.au

Leuze

NOW SERVING

Processing & Packaging Solutions

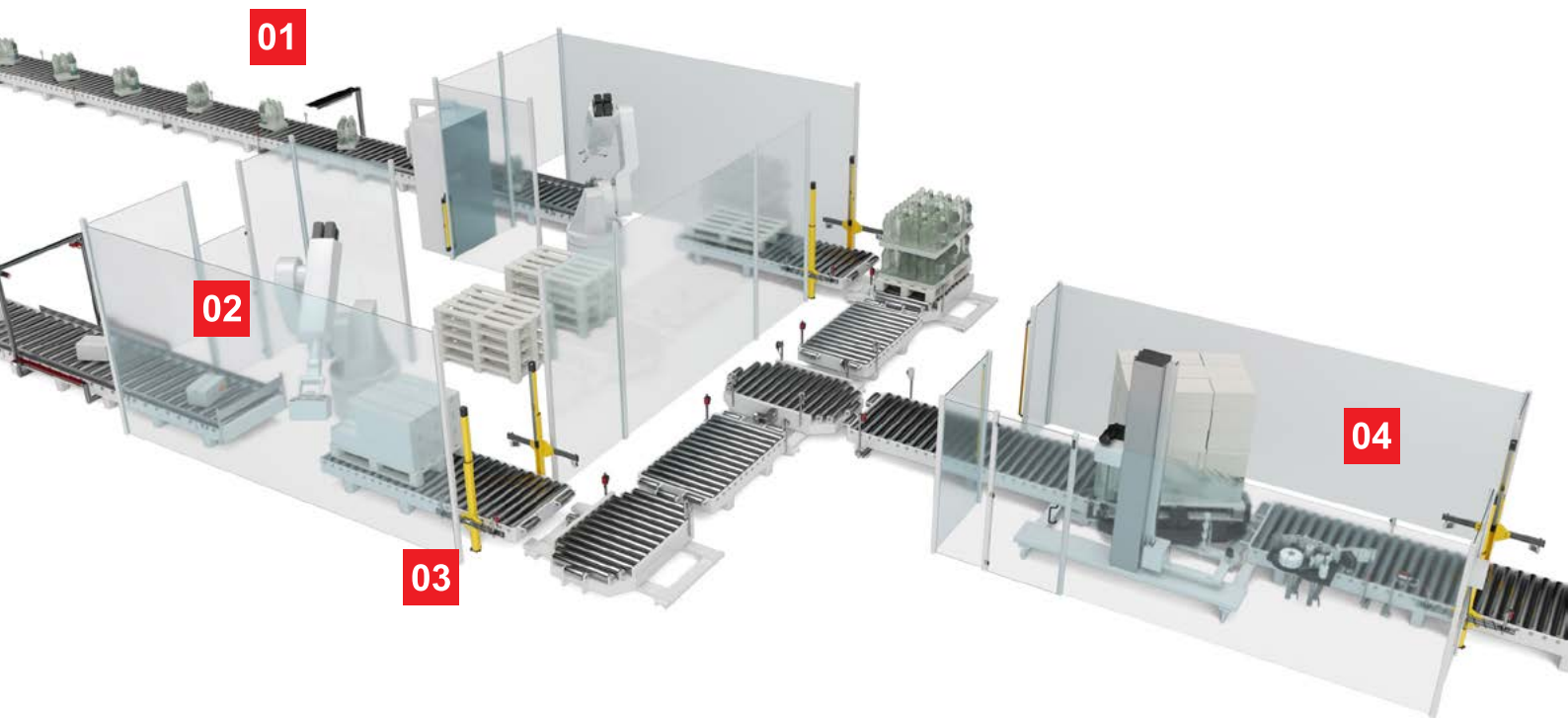

Palletizing



Sensor solutions for palletizing



Requirement:

In the final packaging or palletizing of packages, the presence of the objects is to be checked. Objects with gaps must also be reliably detected.

Solution:

The **PRK 46C retro-reflective photoelectric sensors** have a long operating range and thus a very high function reserve. In other models, the sensitivity can be adjusted, and a Depol function increases the availability of the system. All sensors have a degree of protection IP 69K and ECOLAB certification.

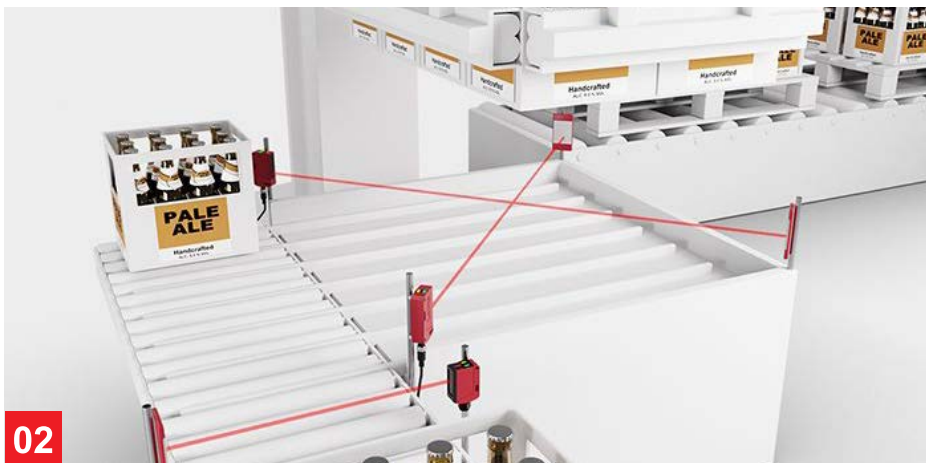

Requirement:

Along transport segments or at transfer points, objects and respective stop positions need detecting. For this purpose, the sensors used must have good alignment capability and high repeatability. Variations of the objects and possible contamination must also be tolerated.

Solution:

The detection and positioning of packages can be solved with different retro-reflective photoelectric sensors. Depending on the required function reserve and dimensions, the **PRK 28**, **PRK 25C** or **PRK 46C** in cubic form and the **PRK 328** in cylindrical form are suitable for these tasks. All sensors have a degree of protection IP 69K and ECOLAB certification.

sales.au@leuze.com

Areas of application

1. Detection of objects
2. Detection and positioning of objects



[PRK 46C](#)



[PRK 28](#)

www.leuze.com.au

Sensor solutions for palletizing

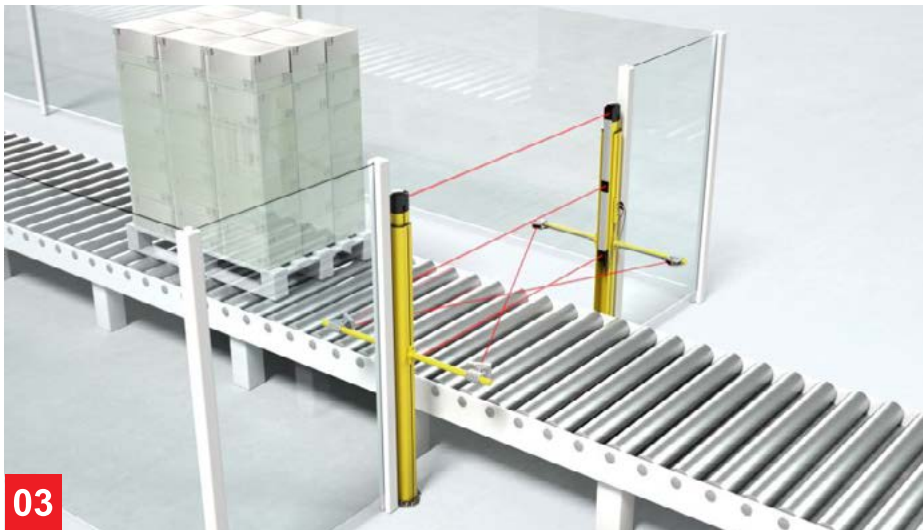

Requirement:

Access guarding on conveyor lines is to prevent persons from accessing a potential danger zone, while at the same time allowing the transported goods to pass through.

Solution:

The muting function bridges the safety sensor during the passage of the transported goods. This function is already integrated in the **MLD 530 multiple light beam safety devices** and in the MLC 530 safety light curtains.

The **MLDSET protective sensor sets** offer complete solutions for access guarding with muting function.



Requirement:

After palletizing and successful load securing, the goods code on the attached bar code labels is to be read in and transferred to the higher-level goods management system.

Solution:

A bar code reader of the **BCL 500i / BCL 600i series** is used to read the pallet label. Integrated fieldbus networkability is one of the key features of this series and enables fast connection to different controls. The CRT technology enables damaged codes to be read reliably.

Areas of application

3. Access guarding with muting

4. Code reading on the pallet



MLDSET



BCL 500i/BCL 600i

Leuze

NOW SERVING

Hazardous Area Solutions

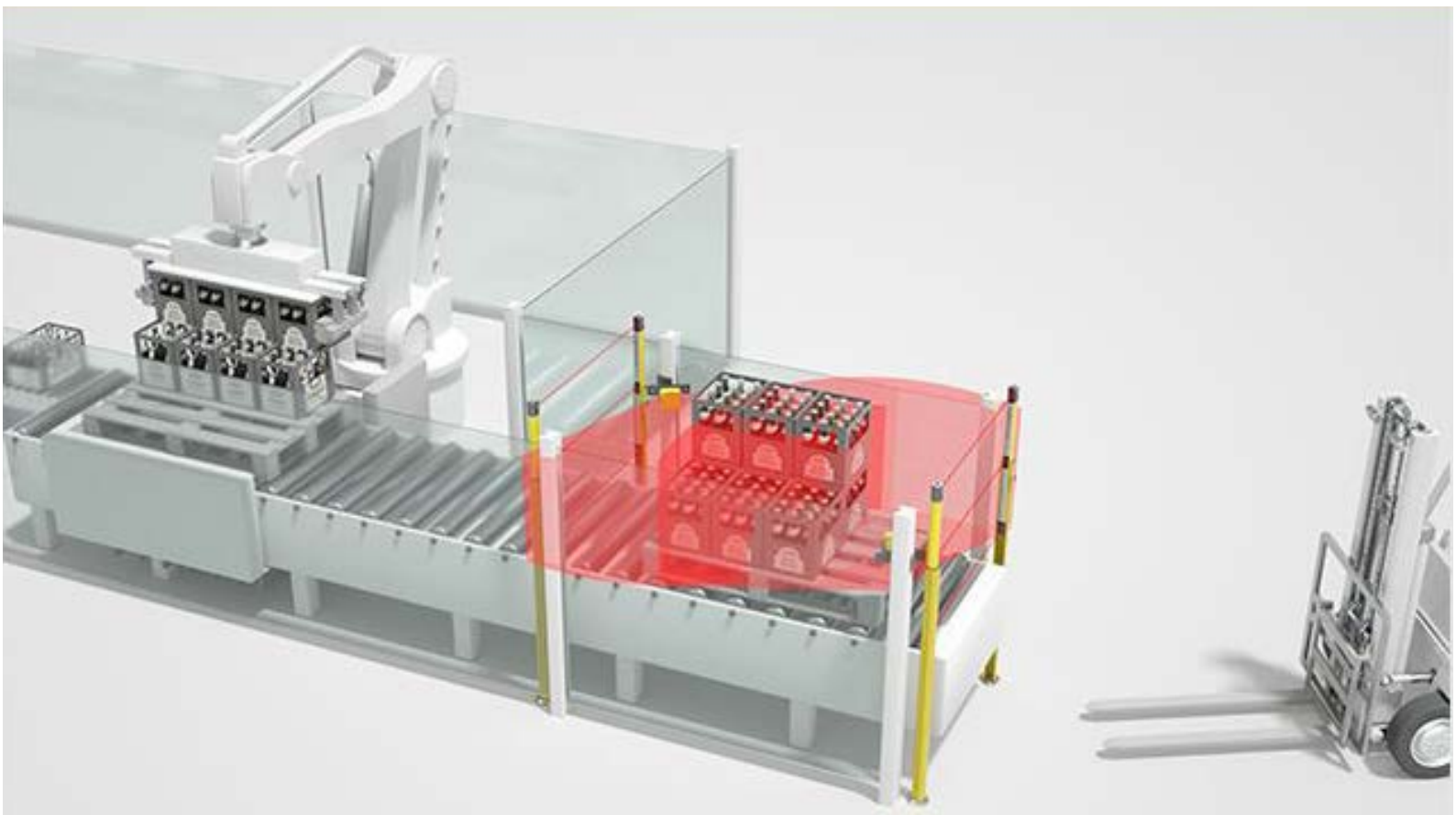

Access guarding



Sensor solutions for access guarding

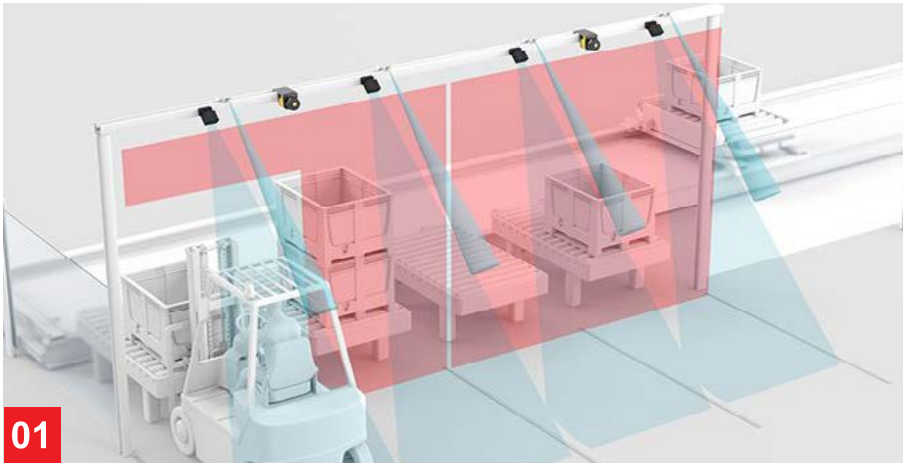

Requirement:

A cross conveyor has several transfer stations at which forklift trucks carry materials in and out. The entire transfer area must be secured against unauthorized access. When a forklift truck approaches, the relevant station must be released for access.

Solution:

Safety laser scanners with a vertically aligned protective field secure the access point. At each station, additional sensors monitor the movement of the forklift trucks and send this information to the safety system. The safety system adjusts the protective field accordingly for access into the station. The entire process is monitored for safety.



Requirement:

Access guarding on conveyor lines is to prevent persons from accessing the danger zone, while at the same time allowing the transported goods to pass through.

Solution:

With Smart Process Gating, the safety sensor is bridged by means of a control signal from the PLC. The function is integrated in the **MLC 530 SPG safety light curtain**. Additional muting sensors are no longer required and the systems have low space requirements thanks to SPG.

sales.au@leuze.com

Areas of application

1. Multi-station access guarding in forklift truck logistics
2. Access guarding on pallet conveyor system



[RSL 400](#)

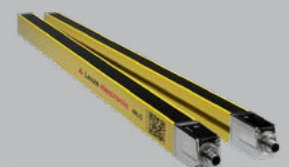

[MLC 530 SPG](#)

www.leuze.com.au

Safety machine guarding



PINNACLE SAFETY MATS

Key Features & Benefits for Food & Beverage Industry:

- **Safety Machine Guarding:** These mats interface with controllers to stop machinery instantly if a person enters a designated hazard zone.
- **No Rust/Non-Corrosive:** The mats do not use rigid steel electrodes, allowing them to withstand wash-down environments without rusting or developing “dead spots”.
- **Durability and Flexibility:** Designed to be highly flexible, resistant to punctures, and able to withstand heavy loads, including trolleys or hand carts.
- **Customization:** Pinnacle provides custom shapes and sizes to fit complex food production layouts, with single mat capabilities up to 6' x 12'.
- **Food Safety Compliance:** The materials are designed to meet stringent safety requirements (such as ANSI/RIA standards).
- **Contamination Control:** The smooth or dual-ribbed surfaces are often easier to clean than traditional matting, reducing the risk of harbouring pathogens.

Application examples

- **Packaging Machinery:** Protecting workers near automated packaging, sealing, and wrapping equipment.
- **Processing Areas:** Monitoring worker access around automated mixing or cooking machinery.
- **Robotic Cells:** Acting as a safety barrier in automated beverage bottling or food palletizing cells.

Areas of application

- Packaging
- Processing
- Robot Cells

Distributor for

- Pinnacle Safety Mats

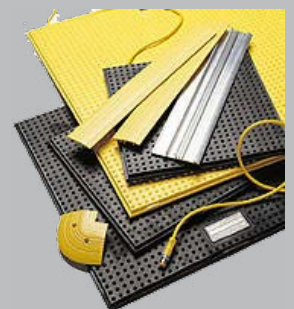

Safety machine guarding

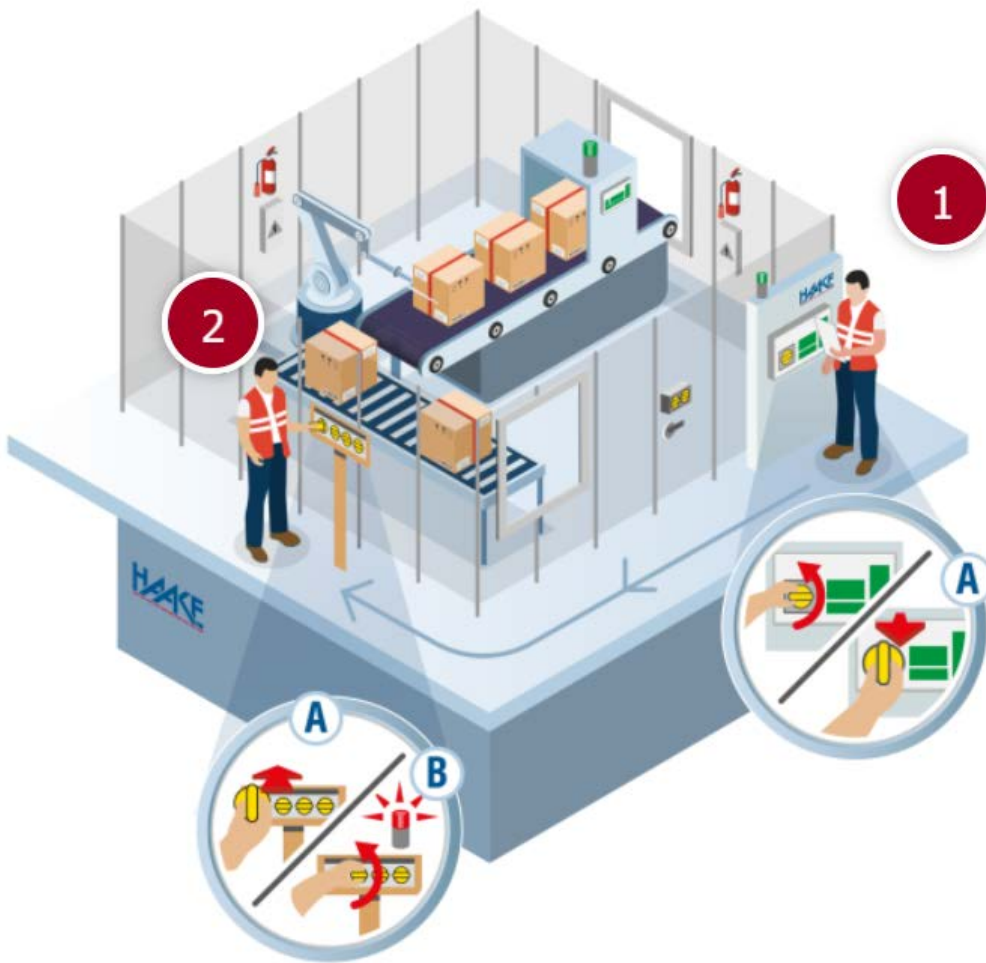

Areas of application

1. Robot shutdown
2. Access to maintenance area

Distributor for

- › Haake trapped key systems

1. Requirement:

To perform maintenance work, the robot must be shut down. At the control panel outside the fenced danger zone.

Solution:

The robot can be shut down by rotating and removing key A from the HAAKE® key operated switch HST®-S.

2. Since the danger zone can be accessed through two guard doors, the use of a HAAKE® key exchange device HST®-W is required. By inserting key A, the differently coded keys B are released. After removing key B, key A is trapped.





Leuze

Leuze sensors are designed for the food and beverage industry focus on hygienic design, high resistance to cleaning agents, and reliable detection in demanding, high-speed environments. Key features include stainless steel housings (V4A/AISI 316L), IP69K protection, and ECOLAB certification



Safety at Leuze

Leuze safety products for the food and beverage industry are characterized by their ability to withstand harsh cleaning environments while maintaining high hygiene standards (Hygienic Design). Key features include IP69K protection, FDA-compliant materials, and resistance to aggressive, caustic cleaning agents, ensuring safe operation in “wash-down” areas



Pizzato Elettrica products, widely used in the food and beverage industry, are designed to meet strict hygiene, safety, and durability requirements, including IP67/IP69K ingress protection for washdown environments, AISI 316L stainless steel construction, and RFID-based tamper-proof technology.



Haake Technik provides specialized safety solutions for the food and beverage industry, focusing on mechanical reliability and hygienic design. Their HST Trapped Key Interlocks and HSB Safety Bumpers are engineered to withstand the rigorous cleaning and environmental demands of food processing facilities.



TR-Electronic provides specialised measurement and control solutions tailored for the food and beverage industry, focusing on maintaining sterile environments and ensuring equipment reliability under harsh cleaning conditions. TR-Electronic's encoders for this sector are designed to withstand aggressive cleaning agents and high-pressure washdowns.



Qlight signalling devices for the food and beverage industry are engineered to meet stringent hygiene, safety, and durability standards, often featuring high-pressure washdown resistance, corrosion resistance, and modular, hygienic designs. Key features include IP67/IP69K protection ratings, stainless steel housing options, and LED technologies that ensure visibility while resisting harsh sanitation chemical agents.



Pinnacle safety mats for the food and beverage industry are primarily designed as pressure-sensitive machine safeguarding systems. These mats, such as the Pinnacle NSD (New Switching Device) system, are used to detect workers near hazardous machinery and trigger immediate stops.

